

Assembly and Operation of the Heathkit Transistor Tester Model IM-36

595-861-03

Heath Company
Benton Harbor,
Michigan 49022

Copyright © 1967

This electronic edition of the Heathkit IM-36 Transistor Tester manual was prepared, by Gary Edwards, garyedwa@hwy.com.au, 3rd November 2004.

It has been partially retyped, and partially scanned to obtain the graphics.

The document was prepared in Word 2000, and converted to *.pdf with Acrobat 5.0

The layout is slightly different than the original, which was altered primarily to economise on space (or number of pages), however apart from the alterations to the layout and some minor formatting changes it contains all of the information from the original document.



Table of Contents

Introduction	2
Parts List	3
Step-by-step Assembly	
Switch Pre-wiring	5
Control Panel Parts Mounting and Initial Wiring	13
Battery Housing Assembly and Wiring	23
Knob Installation	28
Battery Installation	29
Initial Tests and Adjustments.	30
Operational Check	33
Final Assembly	34
Operation	35
Reference Material	41
In Case of Difficulty	41
Troubleshooting Chart	42
Specifications	43
Factory Repair Service	43
Circuit Description	44
Replacement Parts Price List	47
Schematic (fold-out from page)	47

Introduction

The Heathkit Model IM-36 Transistor Tester is a professional quality instrument for shop, laboratory, or remote on-the-job testing of transistors and diodes.

Direct readings of DC Beta (gain) from 0 to 400 and accurate measurements of currents and leakage in transistors permit testing under simulated operating conditions. These conditions are set up by switch-selecting the voltages and currents that are applied to the transistor elements to duplicate published characteristics.

Four lever switches permit eight different tests and measurements, which result in a comparative quality figure (beta, gain) rather than the simple good-bad test made by many other transistor testers.

The self-contained power supply, that consists of seven readily obtainable standard D-cell batteries, makes the instrument fully portable. Since no battery current is drawn unless a transistor is being tested, long battery life is assured.

External voltage sources for higher values of bias, collector, or leak voltages, can be connected to convenient binding posts for higher voltage transistor testing.

Diodes can be tested for forward and reverse characteristics under appropriate current conditions.

By following the step-by-step assembly, test, and operating instructions in the manual, you can build, test, and use this instrument in a few hours.

The attractively styled cabinet, functionally designed control panel, and efficient circuitry, combine to give you a transistor tester that you will use with confidence for many years.

Refer to the "Kit Builders Guide" for complete information on unpacking, parts identification, tools, wiring, soldering, and step-by-step assembly procedures.

Parts List

Note: the numbers in parenthesis in the Parts List are keyed to the numbers on the Parts Pictorial (Fold-out from Page 5).

To order replacement parts, refer to the "Replacement parts Price List" on Page 47 and use the Parts Order Form furnished with this kit.

Note: Precision resistors may be marked in Ω , K Ω , or M Ω . (K Ω equals 1000 Ω , M Ω equals 1,000,000 Ω).

	Part No.	Parts Per Kit	Description
Resistors			
Precision 1%, 0.5 watt.			
(1)	2-148	1	0.09 Ω
	2-148	1	0.9 Ω
	2-229	1	2 Ω
(2)	2-19	1	9 Ω
	2-230	2	18 Ω
	2-24	1	90 Ω

	Part No.	Parts Per Kit	Description
	2-231	2	180Ω
	2-29	1	900Ω
	2-232	1	1800Ω (1.8kΩ)
	2-233	1	2020Ω (2.02kΩ)
	2-35	1	9000Ω (9kΩ)
	2-189	1	18KΩ
	2-156	1	145KΩ
	2-157	1	350KΩ
	2-14	1	1MΩ
	2-158	1	3.5MΩ
	2-17	1	10MΩ
2 watt.			
(3)	2-15-2	1	2Ω 1%
(4)	3-5-2	1	2.2Ω 10% (red-red-gold-silver)
Other Resistances.			
(5)	340-12-1	1	0.01Ω resistance wire.
Capacitors			
(6)	21-48	2	0.05 uf Disc.
Controls			
(7)	11-75	1	20KΩ 2 Watt
(8)	11-79	1	100Ω 4 Watt
Switches			
(9)	62-14	1	3-position 6 wafer 4 lever
(10)	63-440	1	3-position 2-wafer rotary
(11)	63-441	1	10-position 4-wafer rotary
(12)	63-442	1	6-position 3-wafer rotary
(13)	63-443	1	10-position 3-wafer rotary
(14)	63-444	1	6-position 1-wafer rotary
(15)	60-4	1	SPDT Slide
(16)	60-5	1	DPST slide
Wire Harnesses and Wire			
(17)	134-138	1	Main wire harness
(18)	134-152	1	Battery pack wire harness
(19)	134-153	1	Small wire harness
	344-6	1	Red wire
	344-59	1	White wire
Hardware #6			
(20)	250-56	10	6-32 x ¼" screw
(21)	250-89	24	6-32 x 3/8" screw

	Part No.	Parts Per Kit	Description
(22)	250-8	7	#6 x 3/8" sheet metal screw
(23)	255-23	2	6-32 threaded spacer
(24)	252-3	40	6-32 nut
(25)	252-22	8	6-2 speednut
(26)	254-1	15	#6 lockwasher
(27)	253-1	7	#6 fibre flat washer
(28)	253-2	14	#6 fibre shoulder washer
(29)	259-1	23	#6 solder lug

Other Hardware

(30)	250-175	2	2-56 x 3/8" screw
(31)	252-51	2	2-56 nut
(32)	254-7	2	#3 lockwasher

4-40 Hardware

(33)	250-52	4	4-40 x 1/4" screw
(34)	252-2	4	4-40 nut
(35)	254-9	4	#4 lockwasher
(36)	250-107	2	10-24 x 1/4" screw
(37)	254-3	2	#10 lockwasher
(38)	253-6	7	#10 flat fibre washer

Control Hardware

(39)	252-7	7	Control nut
(40)	253-10	7	Control flat washer
(41)	254-4	7	Control lockwasher

Binding Post and Knob Parts

(42)	427-3	9	Binding Post Base
(43)	75-17	18	Binding Post base insulator
(44)	100-16-2	6	Black Binding Post Cap
	100-16-18	3	Red Binding Post Cap
(45)	462-97	4	Lever Switch Knob
(46)	462-245	6	Small Round Knob
(47)	462-253	1	Large Pointer Knob
(48)	455-50	7	Knob bushing

Metal Parts

(49)	203-740-1	1	Panel
(50)	90-502-2	1	Cabinet Shell
(51)	205-307-2	1	Rear Cover
(52)	214-14	1	Battery Housing
(53)	204-413	2	Battery Spacing bracket
(54)	258-43	7	Battery Contact Spring
(55)	211-14	1	Handle

Miscellaneous

(56)	56-10	2	Silicon Diode
------	-------	---	---------------

	Part No.	Parts Per Kit	Description
(57)	407-122	1	Meter (10-0-10 uA)
(58)	434-116	1	Transistor Socket
(59)	260-16	1	Alligator clip
(60)	438-14	2	Alligator clip with adaptor
(61)	261-4	4	Rubber Foot
(62)	261-28	4	Plastic Foot
(63)	207-18	2	3/8" cable clamp
(64)	390-114	1	Battery label
	391-34	1	Blue & white identification label
(65)	490-5	1	Nut starter
	597-308	1	Kit Builders Guide
	597-260	1	Parts Order Form
		1	Manual (See front cover for part number.)
			Solder.

Note: Seven D-cell flashlight batteries (not furnished) will be required for operation of the completed Transistor Tester. You may want to purchase these batteries now to have them ready when you finish assembling the kit.

Step-By-Step Assembly

Before you start to assemble the Transistor Tester, read the Kit Builders Guide for complete information on wiring, soldering, and step-by-step assembly procedures.

As you perform a step in the Step-by-step assembly, first read the step completely through. Then perform the operation as directed. Position each part as wire as shown on the pictorial that accompanies the series of steps. The details provide specific information for individual steps.

Switch Pre-wiring

The assembly of this kit will begin with the pre-wiring of the switches. Before you begin to pre-wire a switch, compare its physical construction with its pictorial so you can identify the contacts and lug positions. Note that each contact **position** has a number, even if it does not have a lug.

To hold the switch firmly while you connect the wires, you may find it convenient to temporarily mount the switch in one of the 3/8" holes in the control panel. Place a towel or soft cloth on your work surface to avoid scratches, and mount the control on the inside of the panel.

Polarity Switch (#63-440)

Note: When wiring some of the parts in this kit, you will be instructed to prepare lengths of wire ahead of time, as in the following steps. To prepare a wire, cut it to the indicated length and remove 1/4" of insulation from each end. The wires are listed in the order in which they will be used.

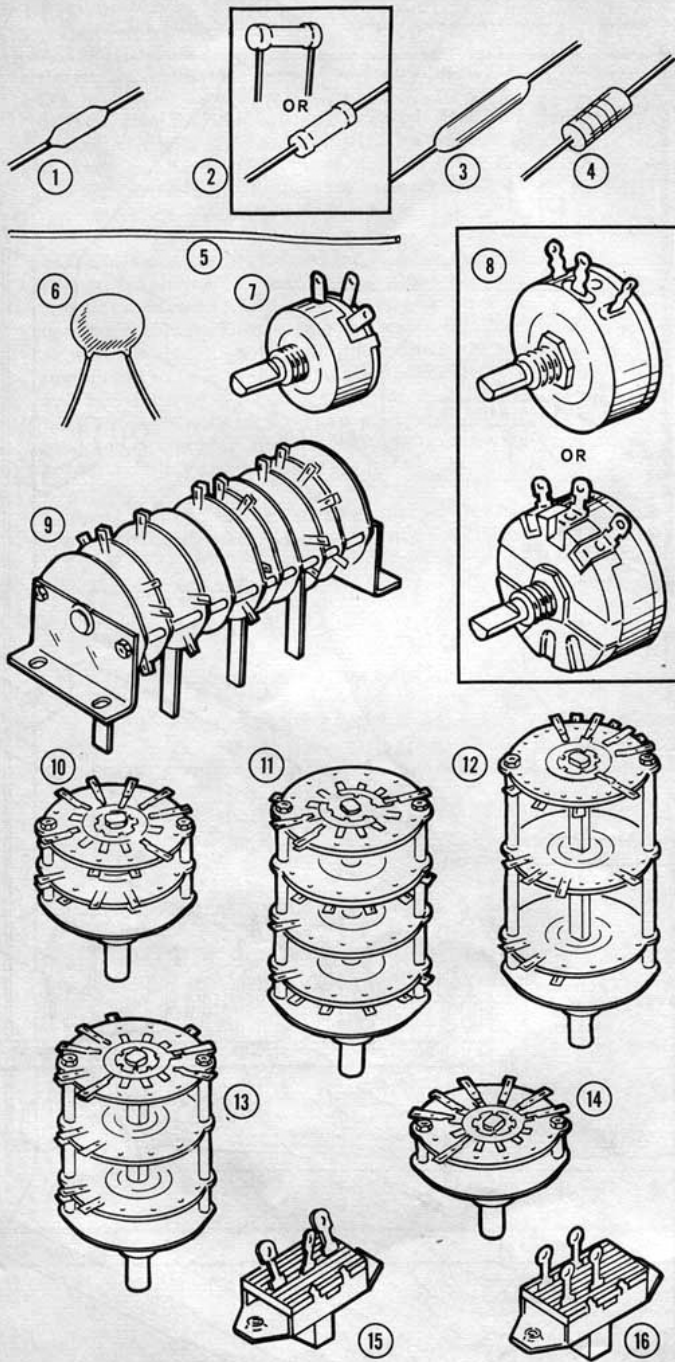

PARTS PICTO

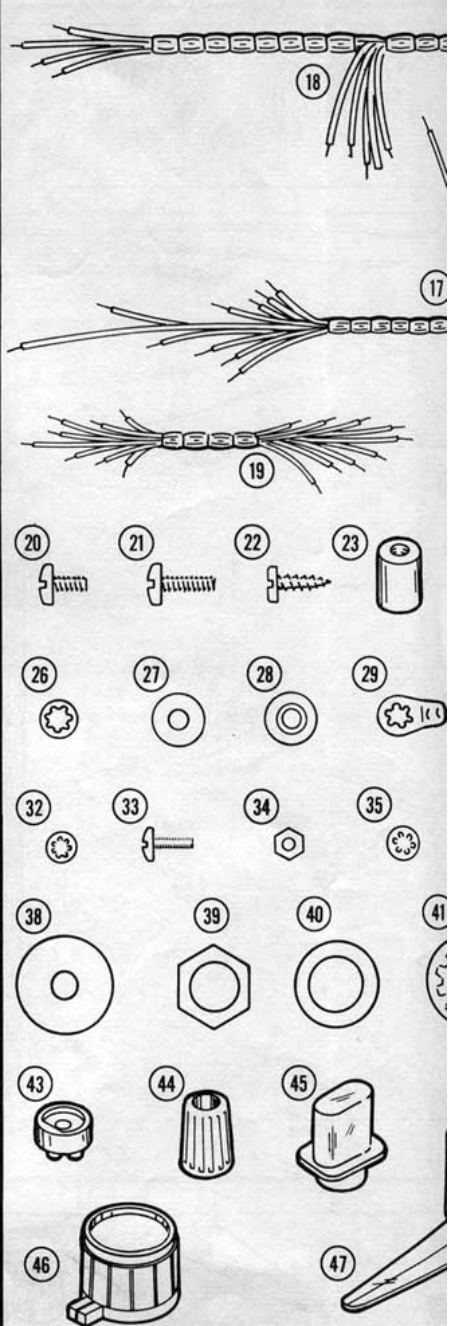

PARTS PICTORIAL

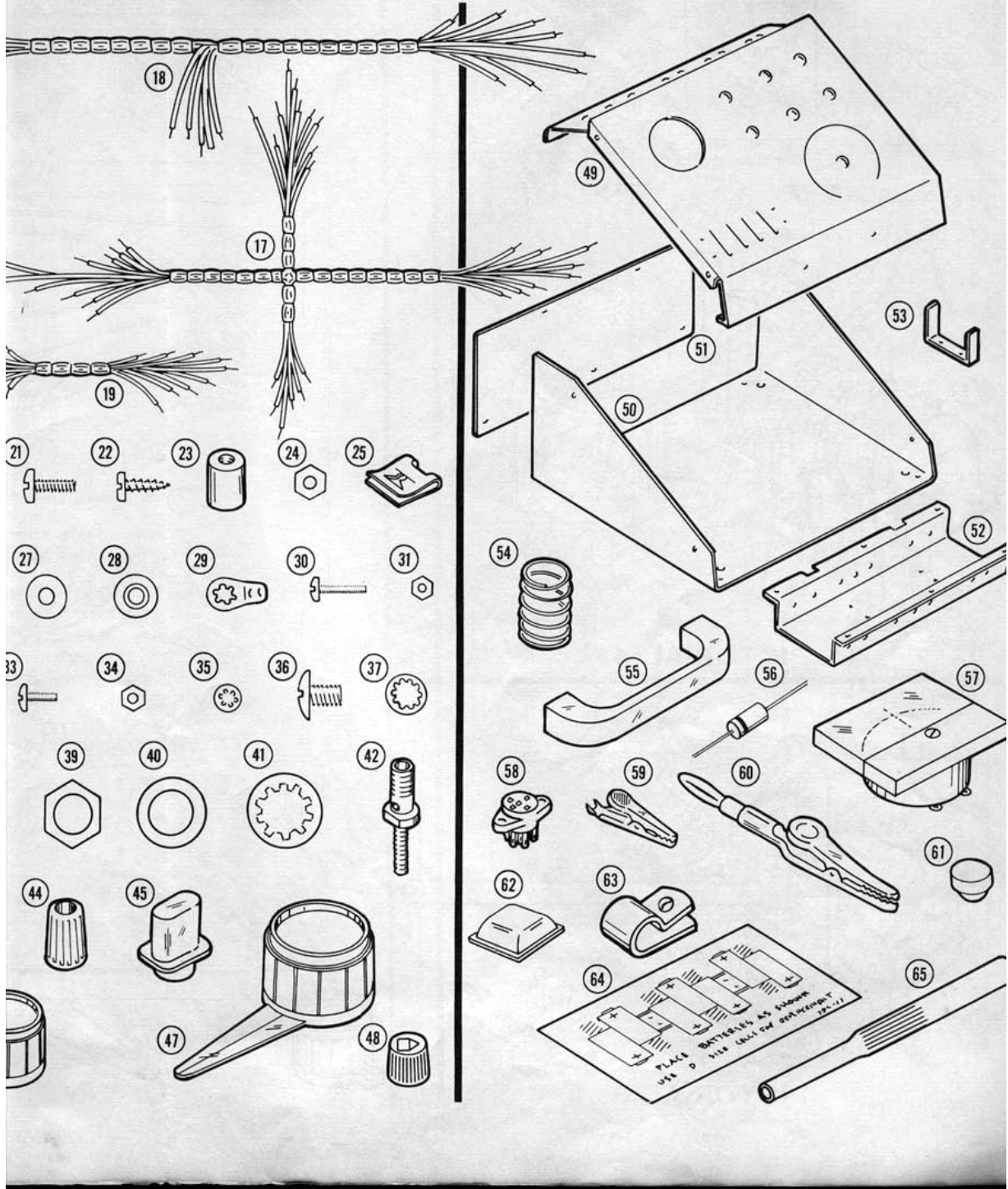

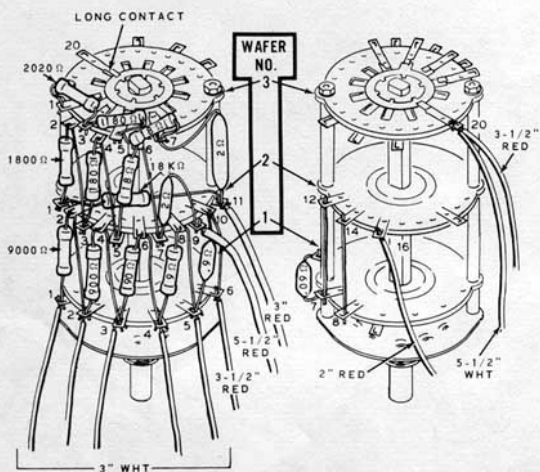
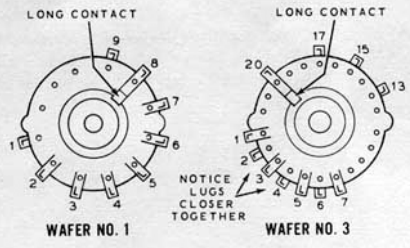

PICTORIAL 4

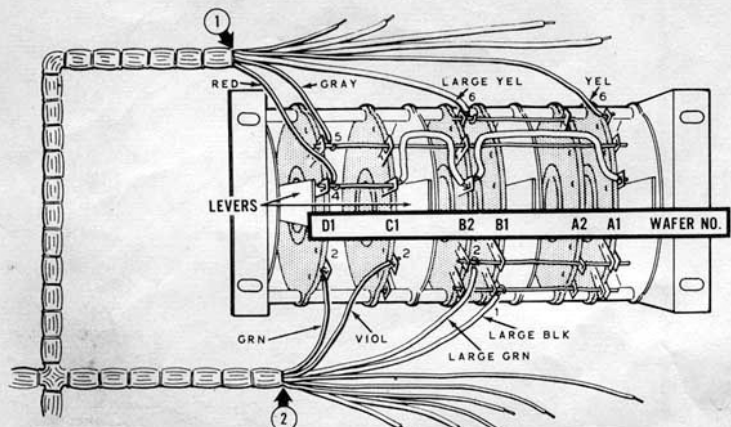

PICTORIAL 6

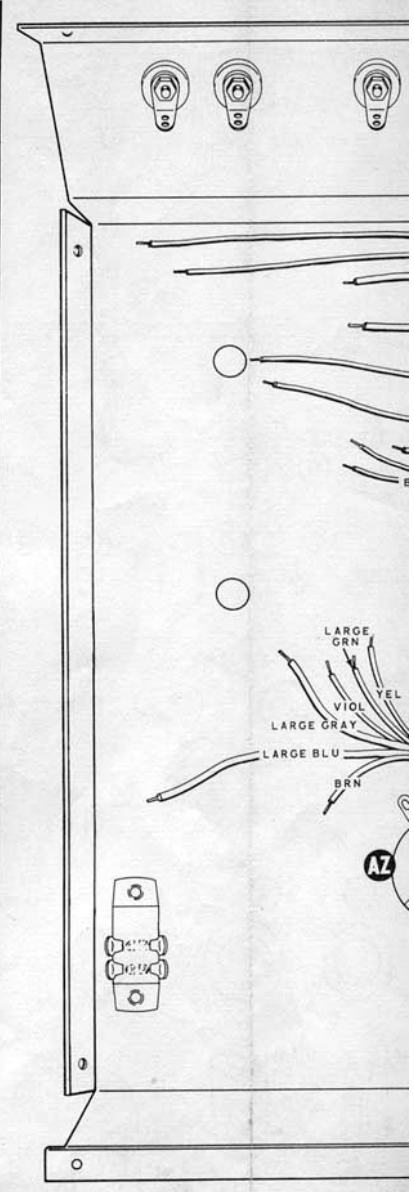

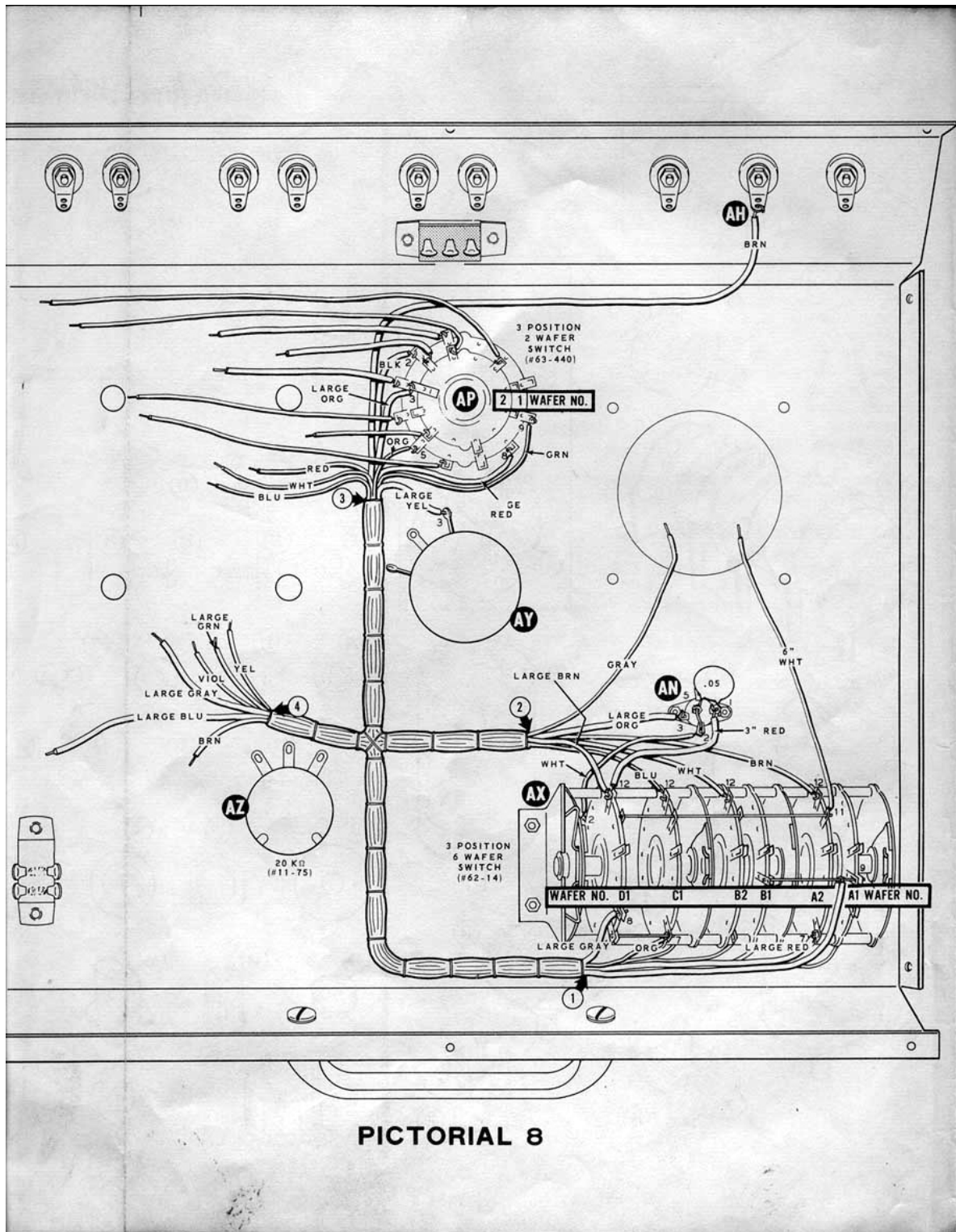

PICTORIAL 8

() Prepare the following lengths of wire:

Wire Colour	Length
Red	3- $\frac{1}{4}$ "
White	4- $\frac{1}{4}$ "
White	4- $\frac{1}{4}$ "
White	6- $\frac{1}{4}$ "
White	8- $\frac{1}{4}$ "
* Red	3- $\frac{1}{2}$ "
* Red	2- $\frac{1}{4}$ "
* Red	2- $\frac{3}{4}$ "

* Remove $\frac{1}{4}$ " of insulation from one end and $\frac{3}{4}$ " of insulation from the other end of these three red wires.

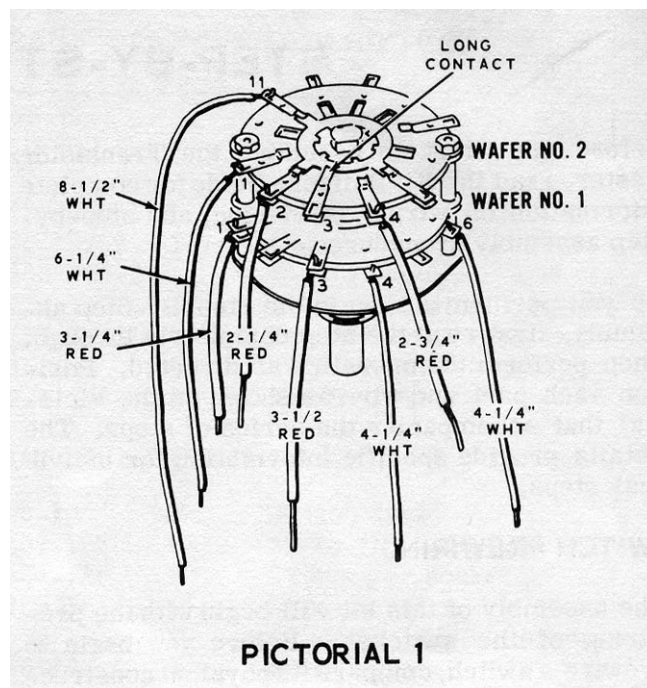

Refer to Pictorial 1 for the following steps.

() Locate the 3-position 2-wafer Polarity switch (#63-440) and compare its wafer and lug positions with those numbered in the Pictorial. Note that the long contact on wafer 2 is identified as lug 3.

Note: Only the switch wafer and lug number will be called out in the following steps. As you connect a wire to a lug, pass the end of the wire through the lug. Then crimp the end of the wire around the lug to hold it in place until you are instructed to solder the connection, be sure to solder the connection, be sure to solder both lugs and the wire.

Connect one end of each of the prepared wires to the 3-position 2-wafer Polarity switch as follows.

- () 3-¼" red to wafer 1 lug 1 (S-1).
- () 4-¼" white to wafer 1 lug 4 (S-1).
- () 4-¼" white to wafer 1 lug 6 (S-1).
- () 6-¼" white to wafer 2 lug 1 (S-1).
- () 8-½" white to wafer 2 lug 11 (S-1).
- () 3-½" red, short end to wafer 1 lug 3 (S-1).
- () 2-¼" red, short end to wafer 2 lug 2 (S-1).
- () 2-¾" red, short end to wafer 2 lug 4 (S-1).

This completes the pre-wiring of the Polarity switch. Set the switch aside until it is called for later.

Collector Voltage Switch (#63-441)

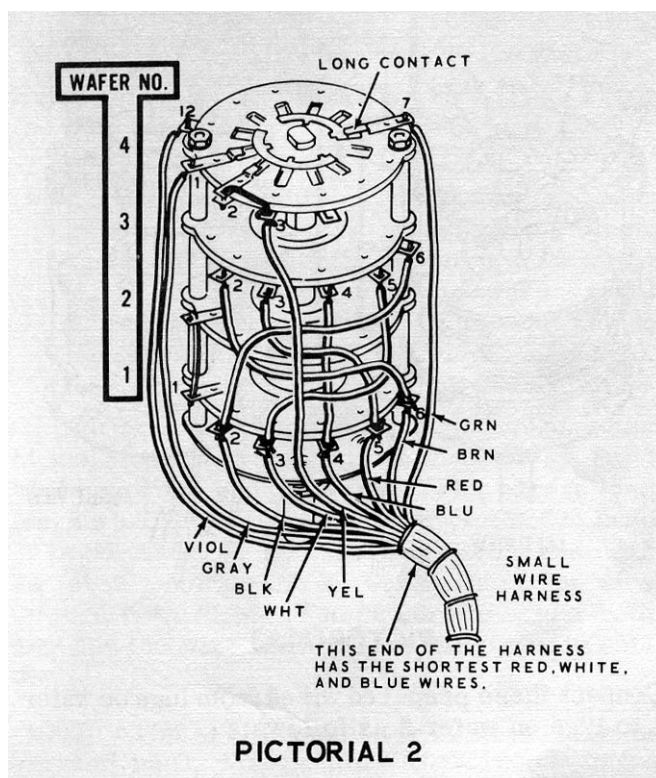

- () Prepare the following lengths of white wire:

1-¼", 1-¾", 2", 2-½", 2-¾"

Refer to Pictorial 2 for the following steps:

- () Locate the 10 position 4 wafer Collector voltage switch (#63-441). Compare the lug positions with those shown in Pictorial 2. Note that the long contact on wafer 4 is lug 7.

Connect the prepared wires from wafer 3 to wafer 1 in the following steps:

- | | Wire | From Wafer 3 | To Wafer 1 |
|-----|------|--------------|------------|
| () | 1-¼" | Lug 4 (NS) | Lug 4 (NS) |

- () 1-³/₄" Lug 3 (NS) Lug 5 (NS)
- () 2-³/₄" Lug 2 (NS) Lug 6 (NS)
- () 2" Lug 5 (NS) Lug 3 (NS)
- () 2-¹/₂" Lug 6 (NS) Lug 2 (NS)

- () Strip the insulation from a 1-¹/₂" length of white wire. Then cut this bare wire into two ³/₄" lengths.

Connect the two ³/₄" bare wires as follows:

- () From wafer 1 lug 1 (NS) to wafer 2 lug 1 (S-1).
- () From wafer 4 lug 3 (NS) to wafer 4 lug 2 (S-1).
- () Locate the small wire harness (#134-153) and note the end that has the shortest red, white and blue wires.

Wires from the end of the wire harness just identified will be connected to the Collector Voltage switch in the following steps. Wires at the other end of the harness will be connected later.

- () Bend the four longest wires back away from the five short wires. This will help avoid accidentally burning any wires while soldering.

Connect the following harness wires to wafer 1 of the switch.

- () Black to lug 2 (S-2).
- () White to lug 3 (S-2).
- () Blue to lug 4 (S-2).
- () Red to lug 5 (S-2).
- () Brown to lug 6 (S-2).

Connect the following harness wires to wafer 4 of the switch.

- () Violet to lug 12 (S-1).
- () Grey to lug 1 (S-1).
- () Yellow to lug 3 (S-2).
- () Green to lug 7 (S-1).
- () Carefully examine the lugs of the switch. All lugs on wafers 1, 2 and 4 that have wires attached should have been soldered, except lug 1 on wafer 1. Lugs 2, 3, 4, 5 and 6 of wafer 3 have wires that are not soldered.

This completes the pre-wiring of the Collector Voltage switch. Set the switch aside until it is called for later.

Leak Voltage Switch (#63-443)

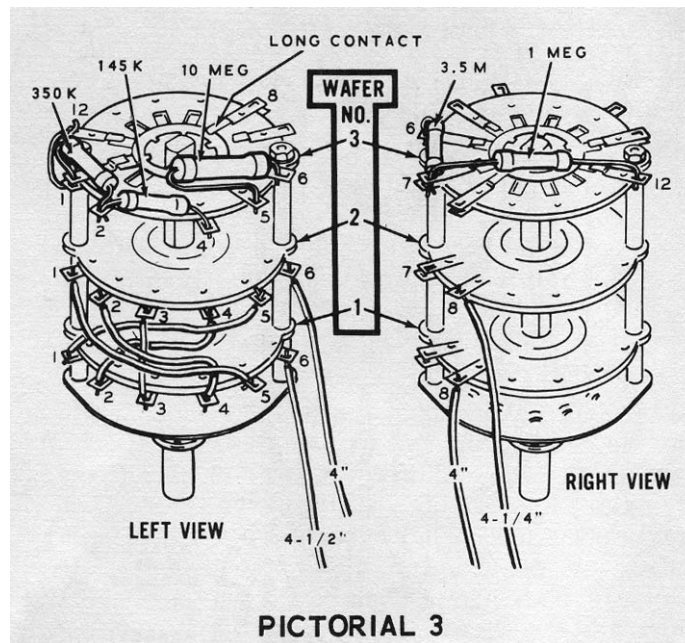

Refer to Pictorial 3 for the following steps.

- () Locate the 10-position 3-wafer Leak Voltage switch (#63-443). Compare the switch with Pictorial 3 so that you can identify the lug numbers. Notice that lug 8 is the long contact on wafer 3.

Note: When you connect a precision resistor, as in the following steps, do not handle the resistor body with pliers or other tools. Preshape the resistor leads so its body can be positioned as shown in the Pictorial; then cut off the excess lead lengths after the resistor is installed.

The following 1% precision resistors will be connected to the lugs on wafer 3 of the Leak Voltage switch. Position each resistor as shown in Pictorial 3.

- () 145K Ω from lug 4 (NS) to lug 2 (NS)
- () 10 M Ω from lug 5 (S-1) to lug 6 (NS)
- () 3.5 M Ω from lug 6 (NS) to lug 7 (NS).
- () 1 M Ω from lug 7 (NS) to lug 12 (NS)

Note: Where a wire passes through one lug then goes to another point, as in the following step, it will count as two wires in the soldering instruction (S-2) one entering and one leaving.

- () Pass one lead of the 350K Ω precision resistor through lug 1 (NS) to lug 12 (NS). Shape the lead away from the switch spacer. Then connect the other lead of this resistor to lug 2 (NS). Now solder lug 1 (NS).
- () Prepare the following lengths of wire.

7/8", 1-3/4", 2 x 1-1/2", 2-1/2"

Connect these prepared wires from lugs on wafer 1 to lugs on wafer 2 as follows.

	Wire	From Wafer 1 Lug	To Wafer 2 lug
()	1- $\frac{3}{4}$ "	1 (NS)	5 (S-1)
()	1- $\frac{1}{2}$ "	2 (NS)	4 (S-1)
()	1- $\frac{1}{2}$ "	4 (NS)	2 (S-1)
()	2- $\frac{1}{2}$ "	5 (NS)	1 (S-1)
()	$\frac{7}{8}$ "	3 (NS)	3 (S-1)

() Prepare the following lengths of wire:

2 x 4", and 2 x 4- $\frac{1}{2}$ "

Connect only one end of each of these prepared wires to lugs on the switch as follows.

() 4- $\frac{1}{2}$ " to wafer 1 lug 6 (S-1).

() 4" to wafer 2 lug 6 (S-1).

() 4" to wafer 1 lug 8 (S-1).

() 4- $\frac{1}{4}$ " to wafer 2 lug 8 (S-1).

(There appears to be a small error here, no 4- $\frac{1}{4}$ " length was prepared)

This completes the wiring of the Leak Voltage switch. Set the switch aside until it is called for later.

Collector Current Switch (#63-442)

Refer to Pictorial 4 (fold-out from page 6) for the following steps.

() Locate the 6-position 3-wafer Collector Current switch (#63-442) and compare its contacts and lugs with those shown in Pictorial 4. Notice that some lugs on wafers 2 and 3 are closer together than the lugs on wafer 1. The long contact on wafer 3 is lug 20.

Caution: Use extra care in making connections to the closely spaced lugs on the switch. Bend wires over the end of the lug. Trim excess lead lengths close to the lug. Be careful not to bend or break a lug. Where there is a front and rear lug at a position on a wafer, pass the wire through both lugs. Then be sure to solder both lugs and the wire when you are instructed to solder.

Note: The 1% precision resistors may be marked in Ω , K Ω , or M Ω (K Ω = 1000 Ω , M Ω = 1,000,000 Ω). For example: 1800 Ω = 1.8K Ω , 2020 Ω = 2.02K Ω . Examine each resistor carefully to be sure you install the correct value each time. As you install a resistor on the switch, pre-shape the leads so the resistor body can be positioned as shown in Pictorial 4.

Read each step completely through first; then perform the operation described in the step. Connect both leads of each resistor before you solder either lead.

In the following steps, you will connect 1% precision resistors to lugs on the wafers of the Collector Current switch.

- () Connect the 18K Ω resistor from lug 1 (NS) to lug 11 (NS) on wafer 2. Position the resistor away from the movable parts of the switch.
- () Pass one end of the 1800 Ω (1.8K Ω) through lug 2 on wafer 3 (S-2) to lug 3 on wafer 2 (NS). Connect the other end of this resistor to lug 1 on wafer 2 (S-2).
- () Pass one lead of a 180 Ω resistor through lug 4 on wafer 3 (S-2) to lug 5 on wafer 2 (NS). Connect the other lead to lug 3 on wafer 2 (S-2).
- () Pass one lead of an 18 Ω resistor through lug 6 on wafer 3 (S-2) to lug 7 on wafer 2 (NS). Connect the other lead to lug 5 on wafer 2 (S-2).
- () Connect the 2 Ω **0.5 watt** precision resistor from lug 7 on wafer 2 (NS) to lug 9 on wafer 2 (NS).
- () Connect the 2 Ω **2 watt** precision resistor from lug 11 on wafer 2 (NS) to lug 7 on wafer 3 (NS).
- () Connect the remaining 18 Ω precision resistor from lug 7 (S-2) to lug 5 (NS) on wafer 3.
- () Connect the remaining 180 Ω precision resistor from lug 5 (S-2) to lug 3 (NS) on wafer 3.
- () Connect the 2020 Ω (2.02 K Ω) resistor from lug 3 (S-2) to lug 1 (S-1) on wafer 3.
- () Connect the 0.09 Ω resistor from lug 6 (NS) to lug 7 (NS) on wafer 1.
- () Pass one lead of the 0.9 Ω resistor through lug 10 on wafer 2 (S-2) to lug 6 on wafer 1 (NS). Connect the other lead to lug 5 on wafer 1 (NS).
- () Pass one lead of the 9 Ω resistor through lug 8 on wafer 2 (S-2) to lug 5 on wafer 1 (NS). Connect the other lead to lug 4 on wafer 1 (NS).
- () Pass one lead of the 90 Ω resistor through lug 6 on wafer 2 (S-2) to lug 4 on wafer 1 (NS). Connect the other lead to lug 3 on wafer 1 (NS).
- () Connect the 900 Ω resistor from lug 4 on wafer 2 (NS) to lug 2 on wafer 1 (NS).
- () Remove the insulation from a 1-1/2" white wire. Then connect this wire from lug 4 on wafer 2 (S-2) to lug 3 on wafer 1 (NS).
- () Pass one lead of the 9000 Ω (9K Ω) resistor through lug 2 on wafer 2 (S-2) to lug 2 on wafer 1 (NS). Connect the other lead to lug 1 on wafer 1 (NS).
- () Remove the insulation from a 2-3/4" length of red wire. Then cut this bare wire into two 1-3/8" lengths.

In the next two steps, you will connect the heavy bare wires you have just prepared.

- () 1-3/8" bare wire from lug 7 on wafer 1 (S-2) to lug 12 on wafer 2 (S-1).
- () 1-3/8" bare wire from lug 8 on wafer 1 (S-1) to lug 14 on wafer 2 (NS).

() Remove $\frac{1}{4}$ " of insulation from each end of a 2" red wire. Then, connect one end of this wire to lug 16 on wafer 2 (S-1). The other end will be connected later.

() Prepare the following lengths of red wire.

3", 2 x 3- $\frac{1}{2}$ ", 5- $\frac{1}{2}$ "

Connect one end of each of these prepared wires in the following steps.

() 3- $\frac{1}{2}$ " to lug 6 on wafer 1 (S-3).

() 5- $\frac{1}{2}$ " to lug 9 on wafer 2 (S-2).

() 3" to lug 11 on wafer 2 (S-3).

() 3- $\frac{1}{2}$ " to lug 20 on wafer 3 (NS).

() Prepare a 5- $\frac{1}{2}$ " white wire, then connect one end of this wire to lug 20 on wafer 3 (S-2).

() Prepare five 3" lengths of white wire.

In the following steps you will connect one end of each of these prepared 3" wires to lugs on wafer 1.

() Lug 1 (NS).

() Lug 2 (S-3).

() Lug 3 (S-3).

() Lug 4 (S-3).

() Lug 5 (S-3).

This completes the pre-wiring of the Collector Current Switch. Set the switch aside until it is called for later.

Lever Switch (#62-14)

Refer to Pictorial 5 for the following steps.

() Locate the 3-position 6-wafer 4-lever switch (#62-14) and compare its sections, wafers, and lugs with those shown in Pictorial 5.

Note: the lever switch contains four separate switch sections, marked A, B, C, and D in Pictorial 5. Sections A and B each have two wafers, while sections C and D each have one wafer. To identify the wafers and lugs on the lever switch, a letter-number combination will be used as follows: The letter will identify the section and the first number will identify the wafer in that section. The number that follows the dash will indicate the lug. For example A2-11 would refer to section A, wafer 2, lug 11.

() Cut the following lengths of red wire (10), then remove the insulation from each of them. (These will be the bare wires used in the steps that follow.)

2 x 3/4", 1", 1-1/4", 1-1/8", 2 x 1-1/2", 2-3/8", 2 x 2-3/4",

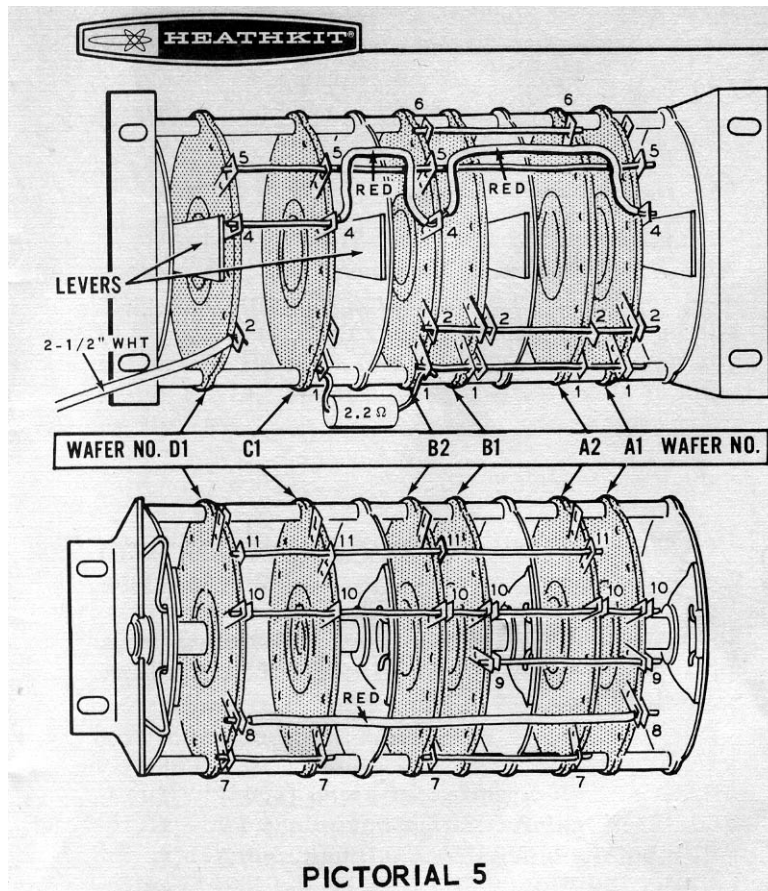

Note: You will connect the bare wires to lugs on the lever switch in the following steps. Pass the wire through the lugs in the order given; then solder only the lugs indicated. Where two lugs appear at a position on a wafer, and you are instructed to solder, be sure to solder both of the lugs and the wire. Be sure none of the bare wires touch any metal parts.

Position the lever switch as shown in the upper part of Pictorial 5. Then connect the prepared bare wires as follows:

- () 1" from B2-6 (S-1) to A2-6 (S-1).
- () 2-3/4" through lug 5 on all wafers. Solder all but D1-5 (NS).
- () 3/4" from D1-4 (S-1) to C1-4 (NS).
- () 1-1/2" through B2-2 (S-1), B1-2 (S2), A2-2 (S-2), A1-2 (S-1).
- () 1-1/2" through B2-1 (NS), B1-1 (S-2), A2-1 (S-2), A1-1 (S-1).
- () Connect the 2.2Ω **2 watt** (red-red-gold-silver) resistor from C1-1 (S-1) to B2-1 (S-2). Position the resistor as shown.
- () Remove 1/4" of insulation from each end of a 2" length of red wire. Then connect this wire from C1-4 (S-2) to B2-4 (NS). Shape and position the wire as shown.

- () Remove ¼" of insulation from each end of a 2-½" length of red wire. Then connect this wire from B2-4 (S-2) to A1-4 (S-1).
- () Remove ¼" of insulation from each end of a 2-½" length of white wire. Then connect one end of this wire to D1-2 (NS). The other end will be connected later.

Position the switch as shown in the lower part of Pictorial 5. Then connect the rest of the prepared bare wires as follows.

- () 1-1/8" from B2-7 (S-1) to A2-7 (NS).
- () ¾" from D1-7 (S-1) to C1-7 (NS).
- () 1-¼" from B1-9 (S-1) to A1-9 (NS).
- () 2-¾" through lug 10 on all wafers. Solder all of the lugs.
- () 2-3/8" through lug 11 on all wafers. Solder all but A2-11 (NS).
- () Connect a 2-7/8" red wire from A1-8 (S-1) to D1-8 (NS).

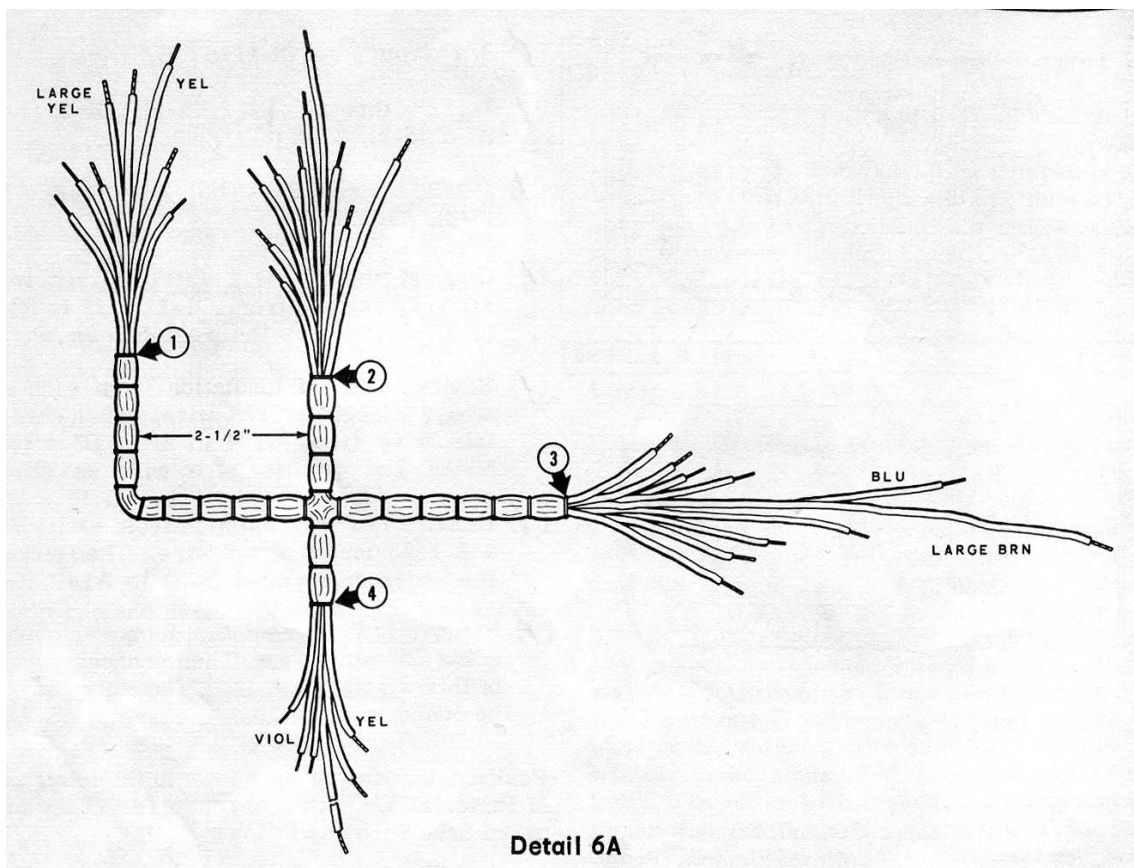

Refer to Pictorial 6 (fold-out from Page 6) for the following steps.

- () Locate the main wire harness (#134-138). Form the harness as shown in Detail 6A. Note that the breakout #1 has a large yellow and small yellow wire, and breakout #3 has a long large brown wire.

- () Position the wire harness and the lever switch as shown in Pictorial 6.

Note: In the following steps, you will connect the harness wires to the lever switch. Some of the switch lugs were left unsoldered to accept the small wires from the harness. When you connect the large wires, form a hook in the end of the wire; then wrap the hook around the bare wire near the specified lug and solder the connection. Small wires are called out by their colors, while large wires are labelled "large". For example, "yellow" and "large yellow."

Connect the wires from breakout #2 as follows:

- () Green to D1-2 (S-2).
- () Violet to C1-2 (S-1).
- () Large green to B2-2 (S-1).
- () Large black to B1-1 (S-1).

Connect the wires from breakout #1 as follows:

- () Gray to D1-5 (S-2).
- () Red to D1-4 (S-2). Note that this lug was soldered previously. Heat the connection; then insert the red wire and resolder.
- () Large yellow to B2-6 (S-1).
- () Yellow to A1-6 (S-1).

The remainder of the harness wires will be connected after the lever switch is installed. Carefully examine the connections on the **lever side** of the switch. Every lug should be connected and soldered. Be sure that no bare wires touch any metal parts. Set the lever switch aside temporarily.

Control Panel Parts and Initial Wiring.

Most of the parts in the Transistor Tester will be mounted and wired on the control panel. The operations in this part of the manual are divided into three sections as follows:

1. Initial parts mounting.
2. Switch mounting and wiring
3. Other parts mounting and wiring.

Initial Parts Mounting.

Refer to Pictorial & (fold-out from page 15) for the following steps.

- () Locate the control panel and position it as shown. Place a towel or soft cloth on your work surface to avoid scratching the panel.

Note: the Heath Company has provided a plastic nut starter with this kit. Use this nut starter to hold and start 2-56, 4-40, and 6-32 nuts on screws. Refer to page 3 of the Kit Builders Guide for further information.

- () Install a binding post base at AA. Use a binding post base, two binding post insulators, a #6 lockwasher, a #6 solder lug, and two 6-32 nuts as shown in Detail 7A.
- () In a like manner, install binding posts at AB, AC, AD, AE, AF, AG, AH, and AJ.
- () Install red binding post caps on the binding posts at AA, AC, and AE. Each of these binding posts is marked (+) on the top of the panel. Turn each cap all the way onto its base.
- () Install black binding post caps on the remaining six binding posts. Turn each cap all the way onto its base.

Note: If you wish to keep the binding posts from falling off when they are loosened, perform the following step at each of the binding posts that were just installed.

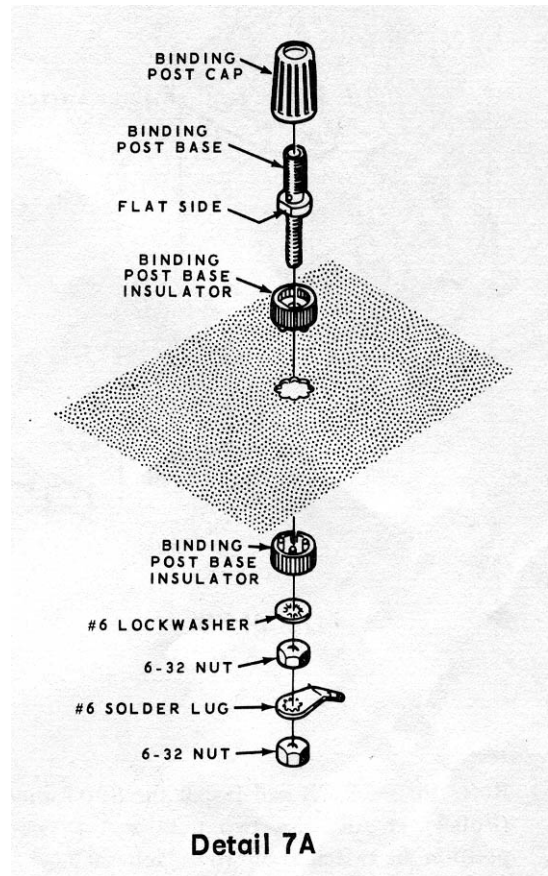

- () Insert the tip of a 1/4" shaft Philips screwdriver into the open end of the binding post cap. Then tap the handle of the screwdriver sharply with a small hammer or tool. Support the binding post so the hammer blow does not crack this insulator or bend the panel.
- () Refer to detail 7B and install the SPDT slide switch (#604) at AK. Use two 6-32 x 1/4" screws and position the switch as show in Pictorial 7.
- () In the same manner, install the DPST slide switch (#60-5) at AL with two 6-32 x 1/4" screws.
- () Install the handle on the front apron of the control panel. Use two 10-24 x 1/4" screws and #10 lockwashers.
- () Refer to Detail 7C and install the transistor socket at AN. Use 2-56 x 3/8" screws, #3 lockwashers, and 2-56 nuts as shown. **Be sure to position the socket so lug 1 is toward the edge of the panel.**

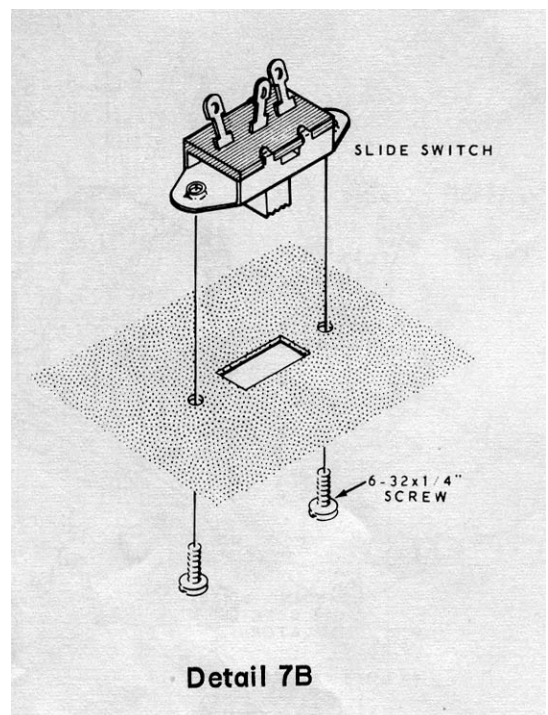

- () This completes the initial control panel

parts mounting. Other parts will be mounted and wired in the following sections.

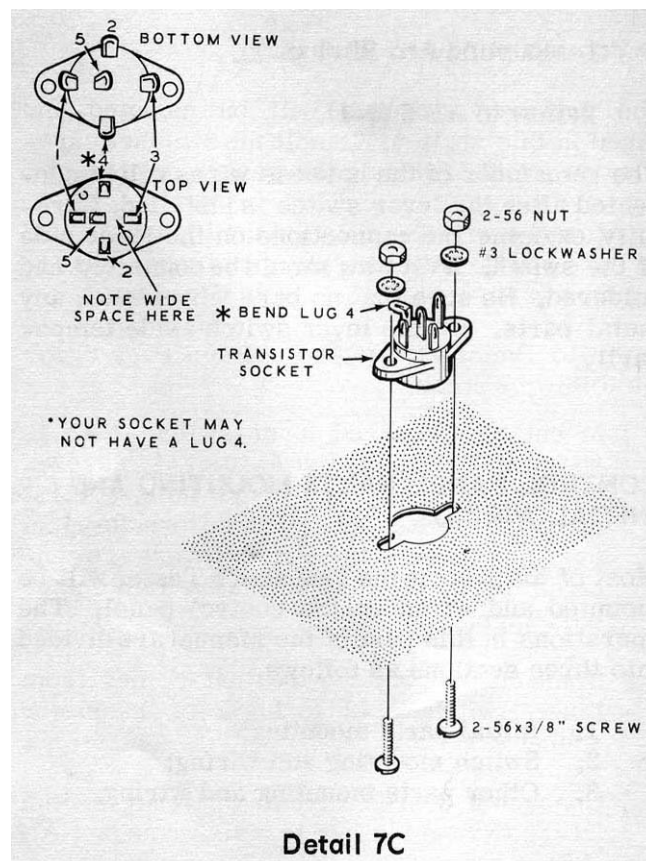

Switch Mounting and Wiring.

The pre-wired switches will be mounted and wired in this section. Handle the switches carefully to avoid damaging the wafers or contacts.

Position the wires as shown in the Pictorials, and be sure you do not pinch any wires under mounting hardware

Refer to Pictorial 8 (fold-out from page 6) for the following steps.

- () Mount the pre-wired lever switch at AX as shown in Detail 8A. Use 4-40 x 1/4" screws, #4 lockwashers, and 4-40 nuts. First mount the switch loosely; then turn the panel over and be sure the switch levers are centred in their slots. Finally, tighten the hardware.
- () Connect the white wire that comes from lever switch D1-2 to lug 2 of transistor socket AN (NS).
- () Connect a 3" red wire from lever switch D1-12 (NS) to lug 1 of transistor socket AN (NS)

- () Connect one lead of a 0.05 uF disc capacitor through lug 5 (S-2) to lug 2 (S-2) of transistor socket AN. Connect the other lead of this capacitor to lug 1 (S-2) of the same socket.
- () Prepare a 6" white wire and connect one end to lever switch A2-11 (S-2). The other end will be connected later.

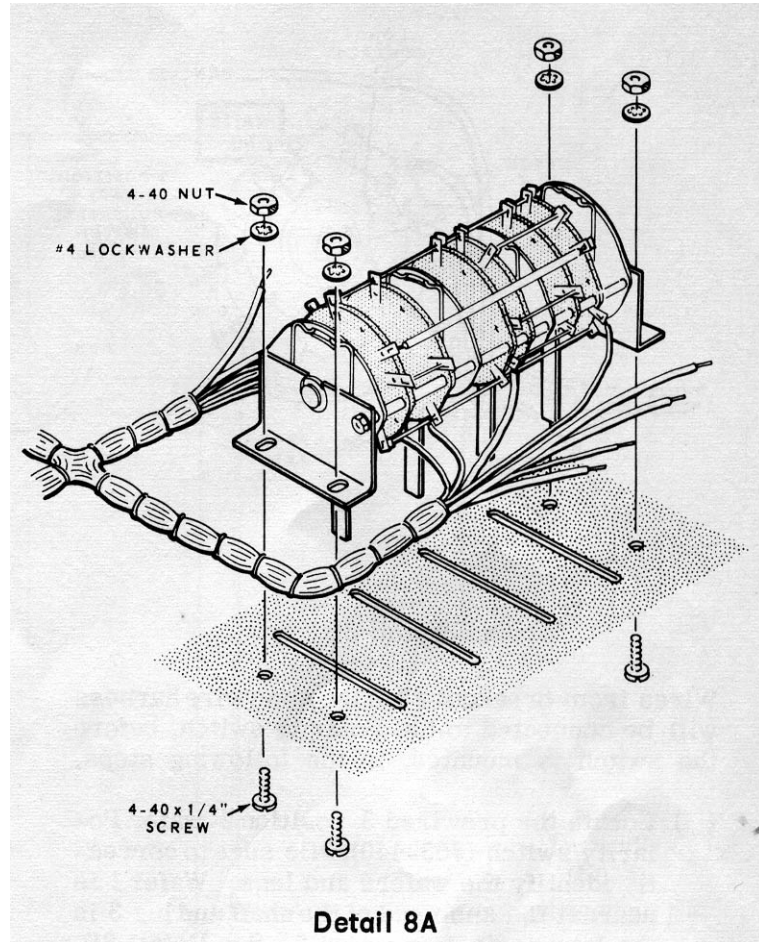

Connect the wires from breakout #2 of the wire harness as follows:

- () Large brown to D1-12 (S-2).
- () Blue to C1-12 (S-1).
- () White to B2-12 (S-1).
- () Brown to A2-12 (S-1).
- () Large orange to lug 3 of transistor socket AN (S-1).

The grey wire from breakout #2 will be connected later.

Connect the wires from breakout #1 to the lever switch as follows:

- () Orange to C1-7 (S-2).
- () Large Grey to D1-8 (S-2).

- () Large red to A2-7 (S-2).
- () Larger blue to A1-9 (S-2).

All wires from breakouts #1 and #2 should now be connected and soldered except one grey wire from breakout #2. This wire will be connected later.

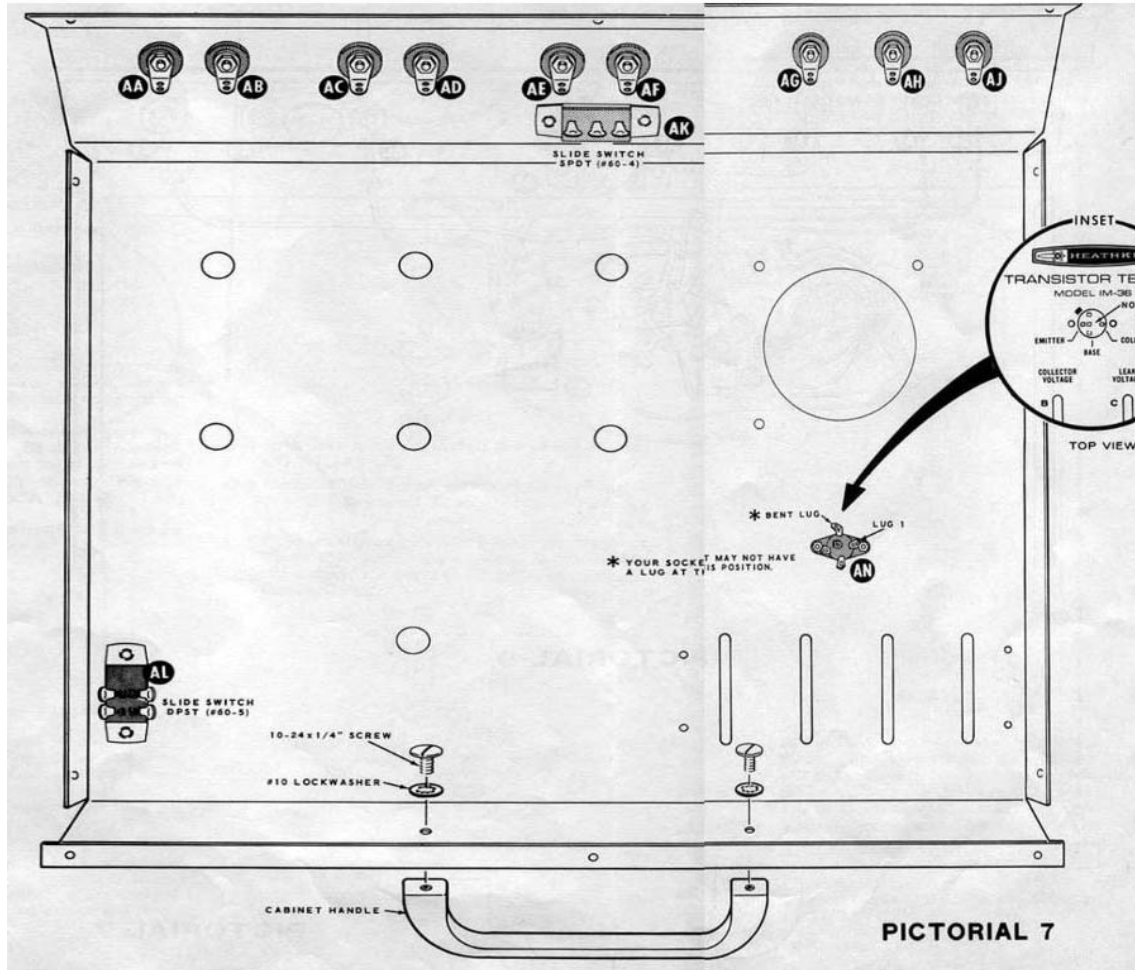

Wires from breakout #3 of the main wire harness will be connected to the Polarity switch, before the switch is mounted, in the following steps.

- () Locate the pre-wired 3-position 2-wafer Polarity switch (#63-440). Be sure to correctly identify the wafers and lugs. Wafer 1 is nearest the knob end of the shaft and lug 3 is the long contact on wafer 2. See detail 8B.

Connect the wires from breakout #3 to the lugs on wafer 1 as follows:

- () Large black to lug 2 (S-1).
- () Orange to lug 5 (S-1).
- () Large red to lug 8 (S-1).
- () Green to lug 9 (NS).
- () Connect the large orange wire to lug 3 on wafer 2 (NS).

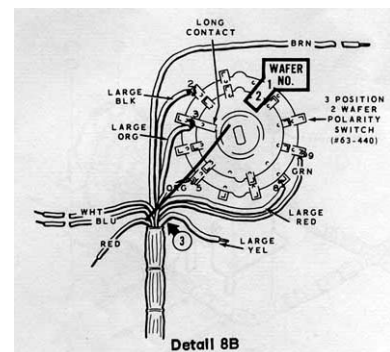

- () Refer to detail 8C and mount the Polarity switch at AP on the front panel. Use a control lockwasher, control flat washer, and a control nut. Position the switch and its wires as shown in Pictorial 8.
- () Install the 100Ω control (#11-79) at AY as shown in Detail 8D. Use a control lockwasher, a control flat washer, and a control nut. Position the control as shown in pictorial 8.
- () In a like manner, install the 20KΩ control (#11-75) at AZ.
- () Connect the large yellow wire from wire harness breakout #3 to lug 3 of control AY (S-1).
- () Connect the long brown wire from breakout #3 to the solder lug at AH (NS). Route this wire along the bend in the panel as shown in the Pictorial.

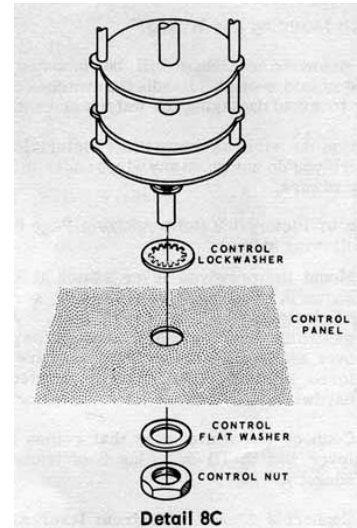

Refer to Pictorial 9 (fold-out from page 16) for the following steps.

- () Mount the pre-wired 10-position 4-wafer Collector voltage switch (#63-441) at AR. Use a control lockwasher, a control flat washer, and a control nut as shown in detail 9A. Position the switch and its wires as shown in Pictorial. Be sure you do not pinch any wires under the mounting hardware.

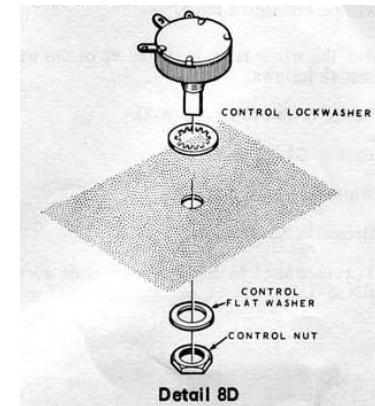

- () Note: Throughout the remainder of the step-by-step assembly instructions, switches will be identified by a letter number combination. For example, the term AP2-11 would refer to switch AP, wafer 2, lug 11.
- () Connect the white wire from AP2-11 to solder lug AA (NS).
- () Connect the white wire from AP2-1 to solder lug AB (NS).
- () Connect the red wire from AP1-1 to AR1-1 (S-2).
- () Connect the red wire that comes from AP1-3 through AR2-12 (S-2) to AR3-12 (S-1)
- () Connect the red wire that comes from AP2-4 through AR1-11 (NS) to AR2-11 (S-1).
- () Prepare the following lengths of wire.

2-¼" red, 2-½" red, 3" red, 5" red, 5" white, 8" white, 8-½" red

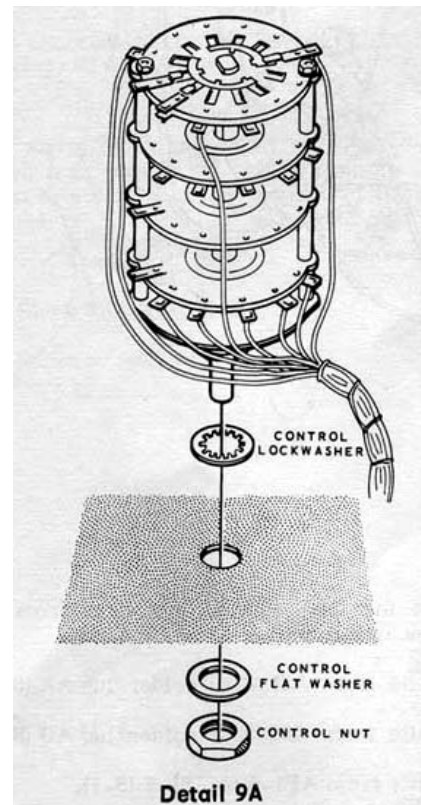

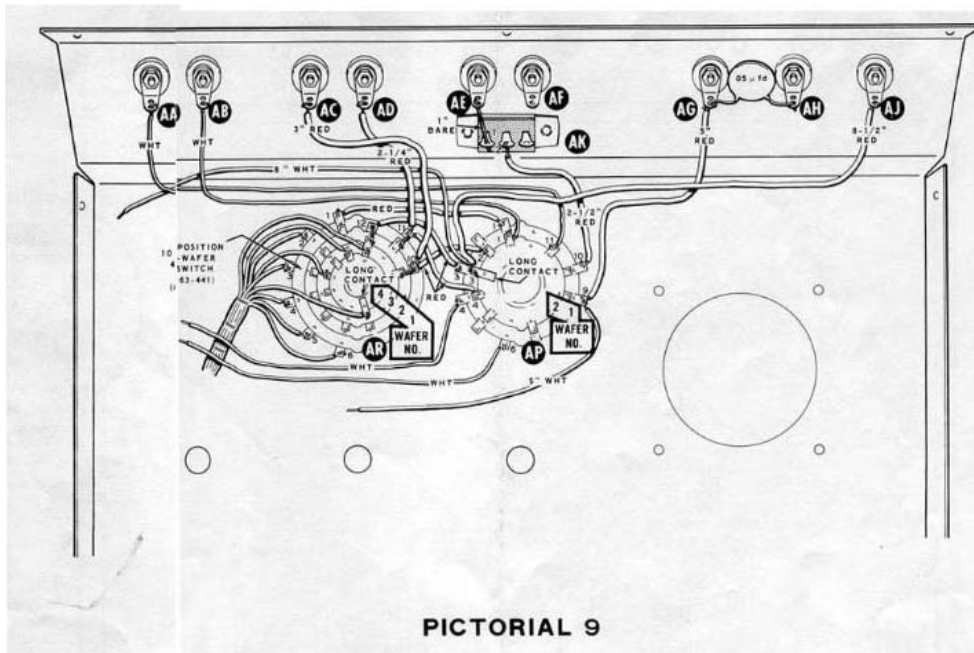

- () Connect a 2-¼" red wire from AR1-11 (S-3) to solder lug AD (S-1).
- () Connect the red wire that comes from LONG AP2-2 through AR2-10 (NS) to AR3-10 (S-1).
- () Connect a 3" red wire from AR2-10 (S-3) to solder lug AC (S-1).
- () Connect a 2-½" red wire from AP1-10 (S-1) to lug 2 of switch AK (S-1).
- () Connect a 5" red wire from AP1-9 (NS) to solder lug AG (NSD).
- () Connect a one end of a 5" white wire to AP1-9 (S-3). The other end will be connected later.
- () Connect an 8-½" red wire from AP2-3 (NS) to solder lug AJ (S-1).
- () Connect one end of an 8" white wire to AP2-3 (S-3). The other end will be connected later.
- () Connect a 0.05 uF disc capacitor from solder lug AG (S-2) to solder lug AH (S-2).
- () Remove the insulation from a 1" red wire. Then connect this bare wire from solder lug AE (S-1) to lug 1 of switch AK (S-1).

Refer to Pictorial 10 for the following steps.

- () Mount the pre-wired 10-position 3-wafer Leak Voltage switch (#63-443) on the control panel at AS. Use a control lockwasher, control flat washer, and a control nut. Position the switch as shown in Pictorial 10. Be sure you do not pinch any wires under the mounting hardware.

Connect the free ends of the wires from the switches as follows:

- () White from AS1-8 to solder lug AA (S-2).

- () White from AS2-8 to solder lug AB (S2).

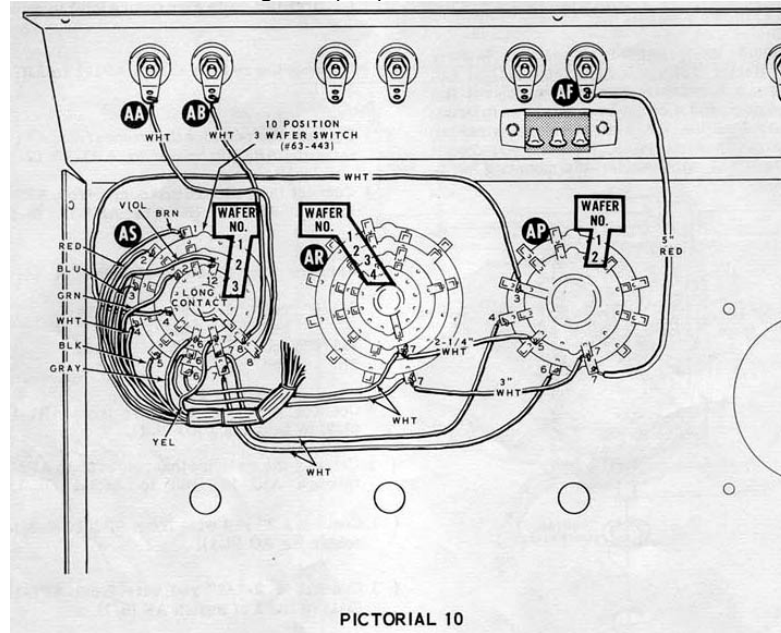

- () White from AP1-6 to AS1-7 (S-1).
- () White from AP1-4 to AS2-7 (S-1).
- () White from AS2-6 to AR1-7 (NS).
- () White from AS1-6 to AR3-7 (NS).

In the next three steps, the length and colour of each wire is called out. Cut the wire to the given length; then remove 1/4" of insulation from each end before connecting the wire.

- () Connect a 3" whiter wire from AR1-7 (S-2) to AP2-7 (NS).
- () Connect a 2-1/4" white wire from AR3-7 (S-2) to AP2-5 (NS).
- () Connect a 5" red wire from solder lug AF (S-1) to AP1-7 (NS).

The wires from the small wire harness that comes from switch AR will be connected in the following steps. Connect the ends of these wires to lugs on wafer 1 of switch AS as follows.

- () Black to AS1-5 (S-2).
- () White to AS1-4 (S-2).
- () Blue to AS1-3 (S-2).
- () Red to AS1-2 (S-2).
- () Brown to AS1 (S-2).

Connect the following small harness wires to wafer 3 of switch AS:

- () Yellow to AS3-7 (S-3).
- () Grey to AS3-6 (S-3).
- () Green to AS3-2 (S-3).
- () Violet to AS3-12 (S-3).
- () Position the wires from the small wire harness as shown in Pictorial 10.
- () Connect the white wire that comes from AP2-3 to AS3-4 (S-2).
- () Carefully examine the lugs on switch AS. Every lug except lug 8 (long contact) on wafer 3 should have been connected and soldered.

Other Parts Mounting and Wiring.

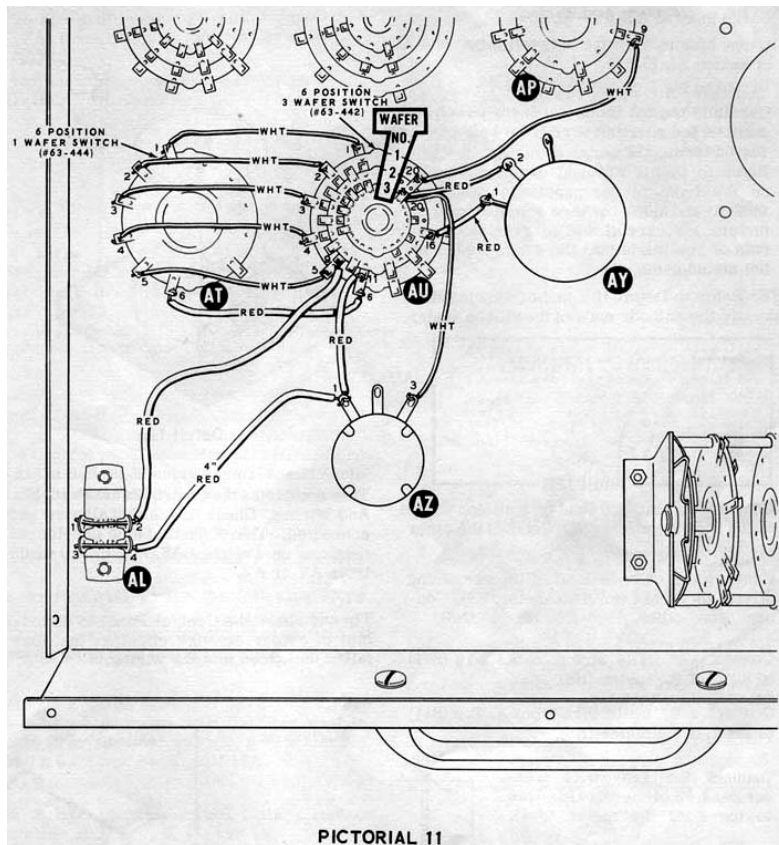

Refer to Pictorial 11 for the following steps.

- () Install the 6-position 1-wafer Base Current switch (#63-442) at AT. Use a control lockwasher, a control flatwasher, and a control nut. Position the switch as shown in the Pictorial.
- () In a like manner, install the pre-wired 6-position 3-wafer Collector Current switch (#63-442) at AU. Be careful not to pinch any wires under the mounting hardware.

In the following steps you will connect the wires that come from lugs on wafer 1 of switch AU to corresponding lugs on switch AT.

- () White from AU1-1 to AT-1 (S-1).
- () White from AU1-2 to AT-2 (S-1).
- () White from AU1-3 to AT-3 (S-1).
- () White from AU1-4 to AT-4 (S-1).
- () White from AU1-5 to AT-5 (S-1).
- () Red from AU1-6 to AT-6 (S-1).
- () Remove an extra $\frac{1}{4}$ " of insulation from the end of the red wire coming from AU2-9. Then pass this end of the wire through lug 2 (S-2) to lug 1 (S-1) of switch AL.
- () Connect the red wire that comes from AU3-20 to lug 2 of control AY (S-1). Move the harness and other wires aside and be careful not to burn any wires with your soldering iron.
- () Connect the red wire that comes from AU2-16 to lug 1 of control AY (S-1).
- () Connect the red wire that comes from AU2-11 to lug 1 of control AZ (NS).
- () Connect the white wire that comes from AU3-20 to lug 3 of control AZ (S-1).
- () Connect the white wire that comes from AP1-9 to AU2-20 (S-1).
- () Remove $\frac{1}{2}$ " of insulation from one end, and $\frac{1}{4}$ " of insulation from the other end, of a 4" red wire. Pass the $\frac{1}{2}$ " bare end through lug 4 (S-2) to lug 3 (S-1) of switch AL. Then connect the other end of this wire to lug 1 of control AZ (S-2).

Refer to Pictorial 12 (fold-out from page 27 for the following steps.)

Connect the remaining wires from breakout #3 of the wire harness as follows:

- () Blue to AS3-8 (S-1).
- () White to AR4-4 (S-1).
- () Red to AU1-1 (S-3).

Connect the wires from breakout #4 as follows:

- () Yellow to AU1-9 (S-1.)
- () Large Green to AU2-14 (S-2).
- () Violet to AU2-10 (S-3). Note that AU2-10 was already soldered. Reheat the lug and connect the wire. Then resolder.)

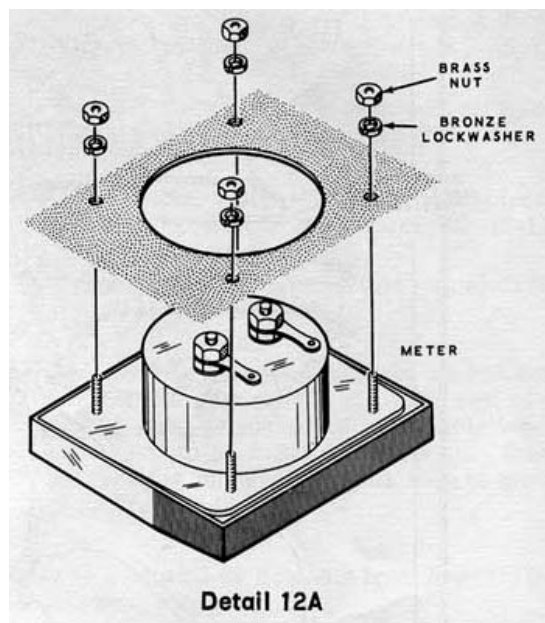

- () Large grey to AT-8 (S-1).
- () Large blue to the wire between lugs 1 and 2 of switch AL (S-1).
- () Carefully unpack the meter from the box and remove the shorting wire from between the meter terminals.
- () Refer to Detail 12A and mount the meter on the front of the panel. Use the lockwasher and nuts that are supplied with the meter. Be careful not to overtighten the nuts or you might pull the screw studs from the meter case.

Note: Refer to Detail 12B in the following steps to identify the cathode ends of the silicon diodes.

- () Connect the cathode lead of a silicon diode to lug 1 of the meter (NS). Connect the other end to lug 2 (NS).
- () Connect the cathode end of the remaining silicon diode to lug 2 of the meter (NS). Connect the other end to lug 1 (NS).

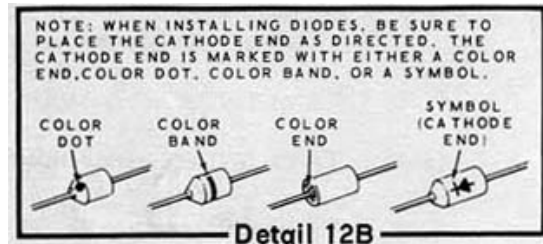

- () Connect a 5" white wire from AP2-10 (S-1) to lug 1 of the meter (NS).
- () Connect a 6" white wire from AP2-9 (S-1) to lug 2 of the meter (S-4).
- () Connect the grey wire from breakout #2 of the wire harness to lug 1 of the meter (S-4).
- () Locate the length of resistance wire (#340-12-1) and shape it as shown in detail 12C. then connect one end of this wire to the bare wire near AU1-7 (S-1). Connect the other end of the resistance wire to the bare wire near D1-10 (S-1).
Do not cut this wire.

This completes the Control Panel Parts Mounting and Wiring. Check to see that all wire ends are connected. There should be no unsoldered connections on switches AS, AT, or AU or on controls AY or AZ.

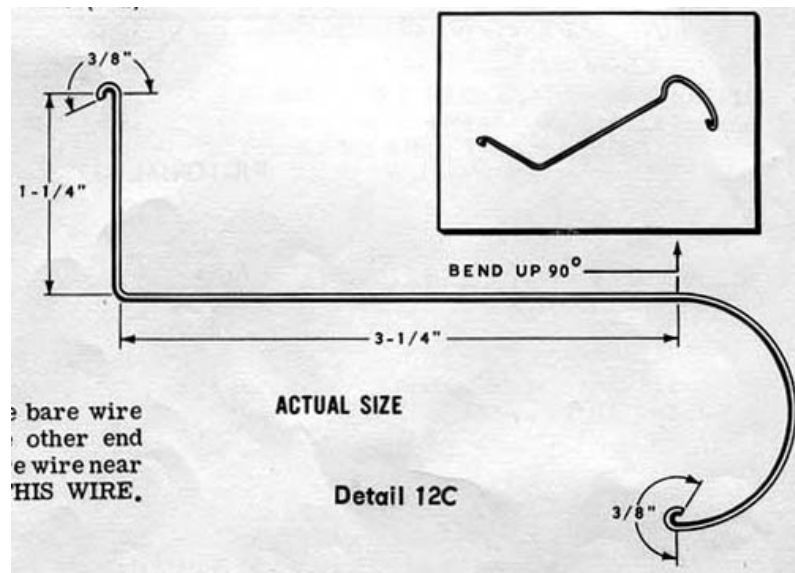

Tip and shake the Control Panel to dislodge any bits of solder or wire clippings that may have fallen unnoticed into the wiring.

Set the control panel aside temporarily and proceed to the Battery Housing Assembly and Wiring instructions that follow.

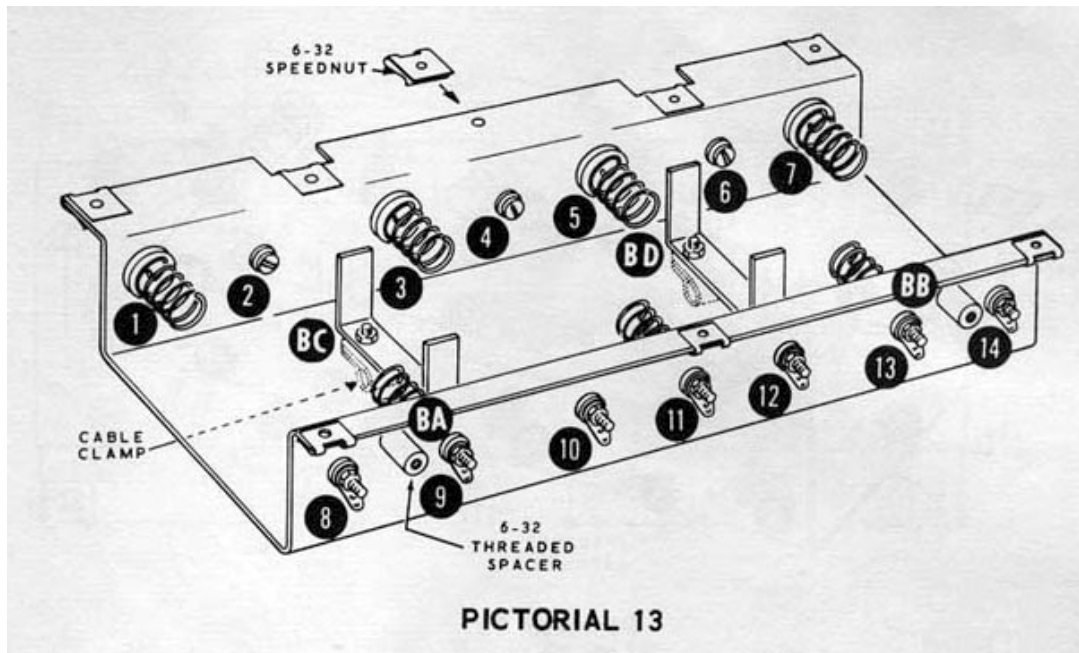

Battery Housing Assembly and Wiring.

Refer to Pictorial 13 for the following steps.

- () Locate the battery housing and position it as shown in this Pictorial.
- () Mount a battery contact spring a 1. Use a 6-32 x 3/8" screw, a #10 flat fibre washer, a #6 fibre shoulder washer, a #6 solder lug, and a 6-32 nut. See Detail 13A
- () In a like manner, install battery contact springs at 3, 5, 7, 9, 11, 13.
- () Refer to detail 13B and install a 6-32 x 3/8" screw, #6 fibre shoulder washer, #6 fibre flat washer, #6 solder lug, and 6-32 nut at 2.
- () In a like manner install similar hardware at 4,6, 8, 10, 12 and 14.
- () Install 6-32 threaded spacers at BA and BB. Use 6-32 x 1/4" screws and #6 lockwashers as shown in detail 13C.
- () Install a battery spacer bracket at BC as show in detail 13D. Use a 6-32 x 1/4" hardware in one mounting hole and 6-32 x 3/8" hardware with a 3/8" cable clamp in the other mounting hole.

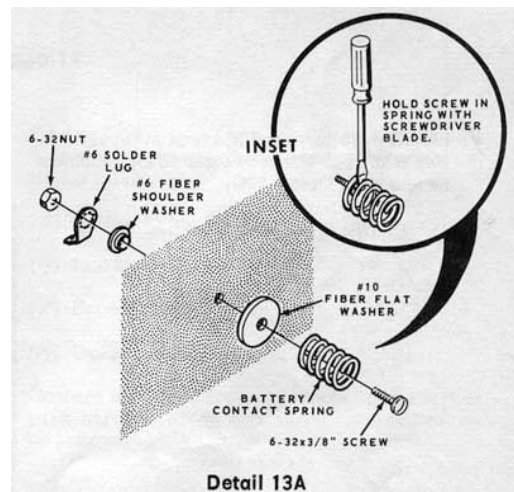

- () In a like manner, install the other battery spacer bracket and cable clam at BD.
- () Install 6-32 speednuts at each of the holes on the battery housing flange as shown in Pictorial 13. Be sure that the flat side of each speednut faces upward.

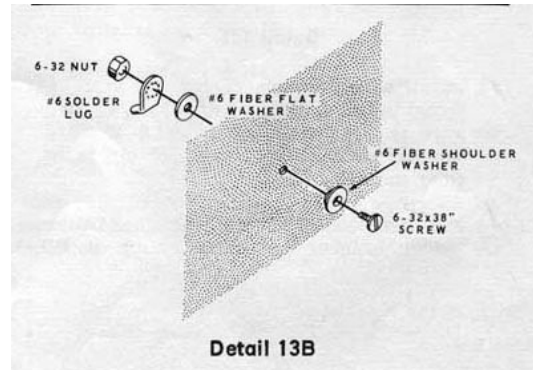

Position the battery housing as shown in Pictorial 14 for the following steps.

- () Locate the battery pack wire harness and pass the four wires of breakout #3 through both cable clamps as shown in the pictorial.
- () Prepare the following lengths of bare wire. To prepare the bare wire, first cut the indicated lengths of red wire. Then remove all the insulation from each length.

3 x 1-3/4", and 2 x 2-1/4"

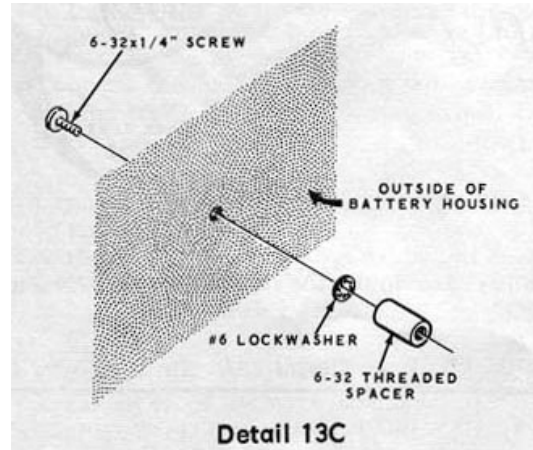

Connect these bare wires to the solder lugs on the battery pack as follows:

- () 2-1/4" from lug 2 (NS) to lug 3 (S-1).
- () 1-3/4" from lug 4 (S-1) to lug 5 (NS).
- () 1-3/4" from lug 8 (S-1) to lug 9 (NS).
- () 1-3/4" from lug 10 (NS) to lug 11 (S-1).
- () 2-1/4" from lug 12 (S-1) to lug 13 (NS).

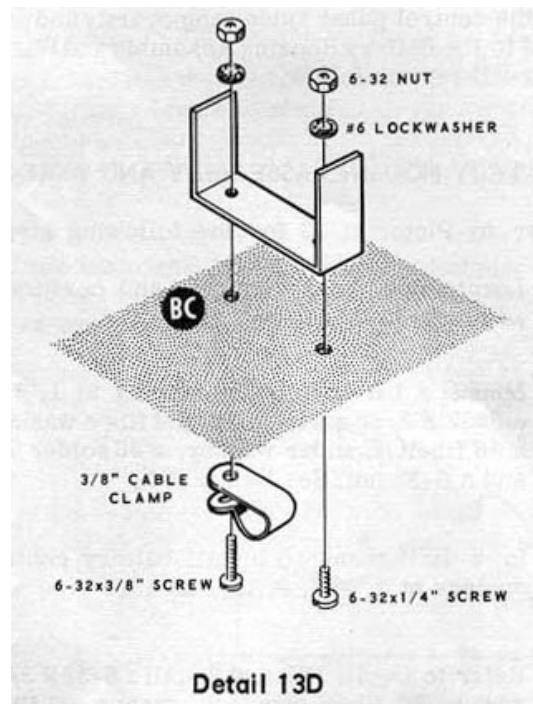

Connect the wires from breakout #3 of the battery pack harness to the lugs on the battery housing as follows:

- () Yellow to lug 1 (S-1).
- () Red to lug 2 (S-2).
- () Brown to lug 9 (S-2).
- () Orange to lug 10 (S-2).

Connect the wires from breakout #2 of the bottom pack harness to the lugs on the battery housing as follows:

- () Black to lug 5 (S-2).

- () Violet to lug 6 (S-1).
- () Green to lug 7 (S-1).
- () Grey to lug 13 (S-2).
- () Blue to lug 14 (S-1).

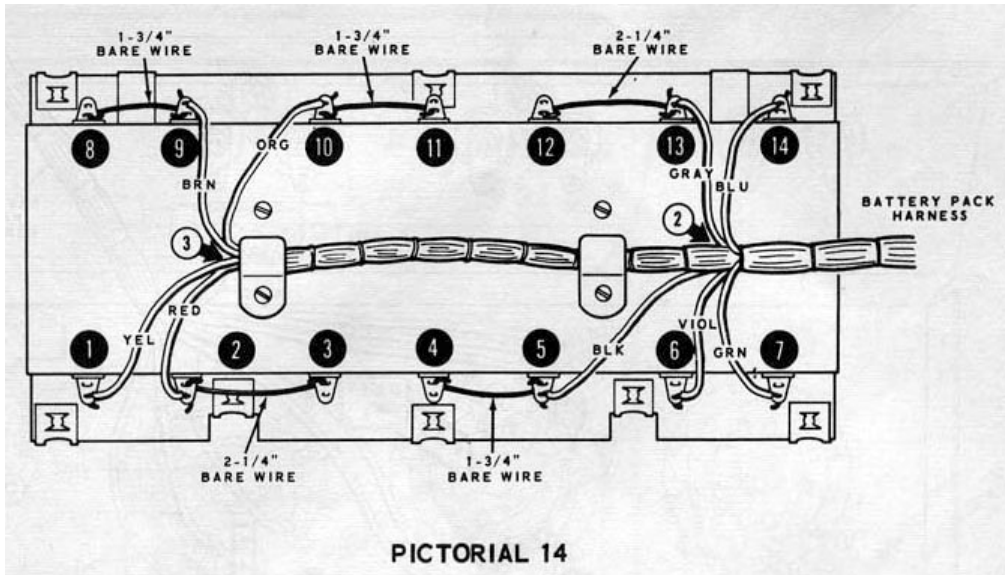

This completes the assembly and wiring of the battery housing. Proceed to the Final Wiring instructions that follow.

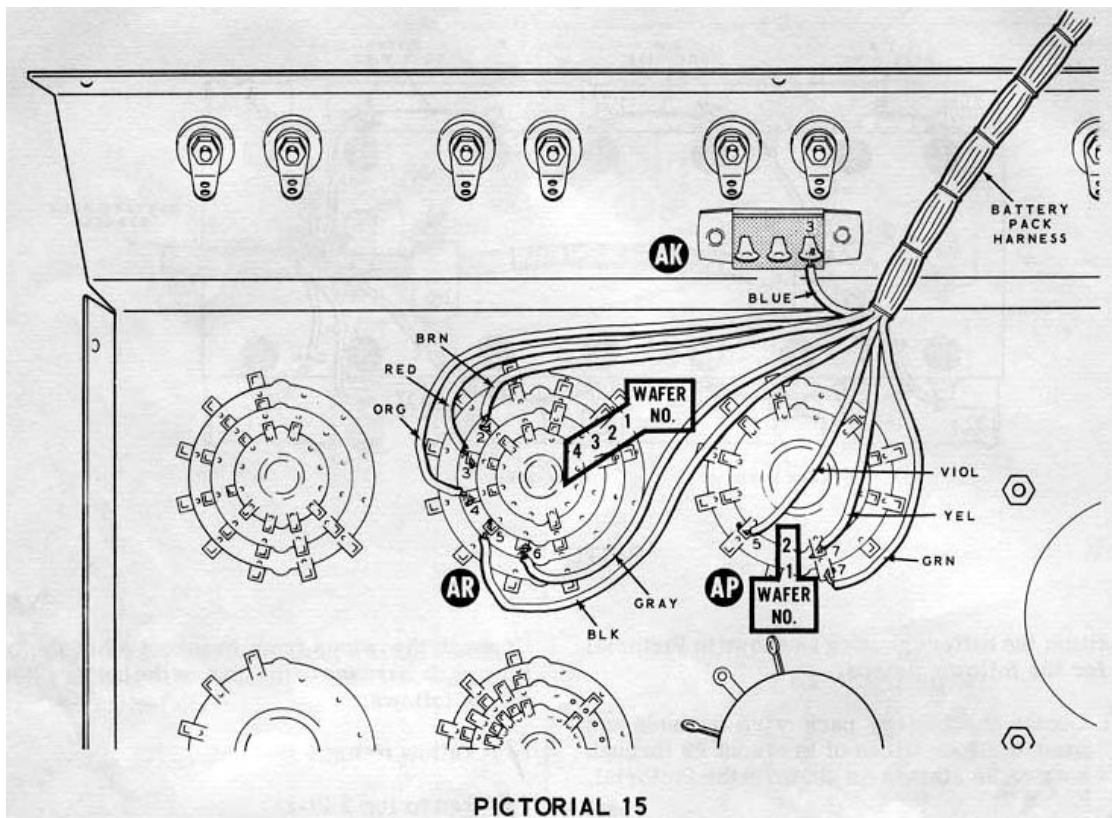

Final Wiring

In the final wiring of your Transistor Tester, the battery pack harness wires will be connected to switches AP and AR. Since there are already several wires connected to these switches, you must be very careful not to accidentally burn any wires with your soldering iron. Move aside any wires that are close.

Refer to pictorial 15 and connect the wires from the battery pack harness as follows:

- () Connect the blue wire to lug 3 of switch AK (S-1).
- () Green to AP1-7 (S-2).
- () Yellow to AP2-7 (S-2).
- () Violet to AP2-5 (S-2).
- () Brown to AR3-2 (S-2).
- () Red to AR3-3 (S-2).
- () Orange to AR3-4 (S-2).
- () Grey to AR3-6 (S-2).
- () Black to AR3-5 (S-2).
- () Locate the alligator clip (#260-16) and connect one end of the 4" red wire as shown in detail 15A.

Lay the alligator clip aside it will be used later.

Refer to Pictorial 16 for the following steps.

- () Mount the battery housing to the top edge of the control panel as shown in the Pictorial. Use three 6-32 x 3/8" screws.
- () Peel away the paper backing from the battery placement label. Then press the label firmly into place in the battery housing as shown in Pictorial 16.

This completes the final wiring of your Transistor Tester. Tip and shake the assembly to dislodge any bits of solder or wire ends that may have fallen unnoticed into the wiring.

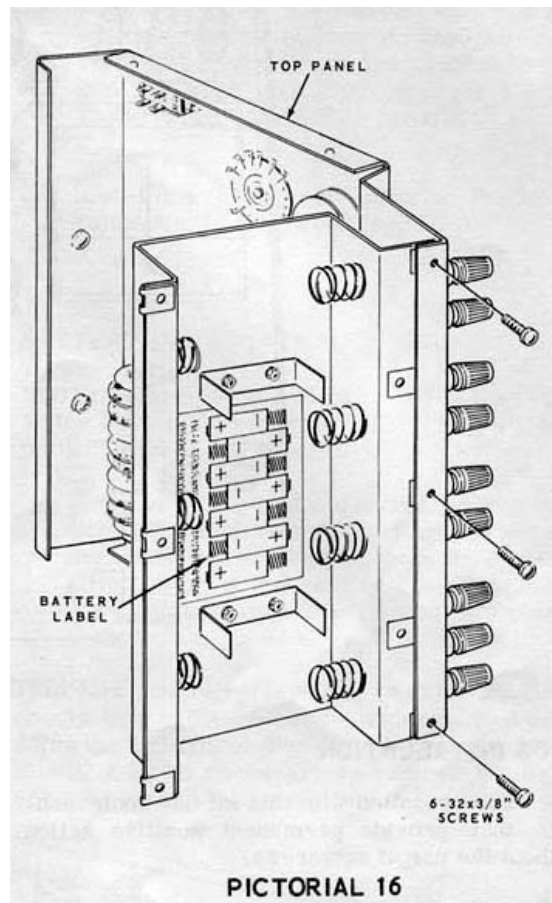
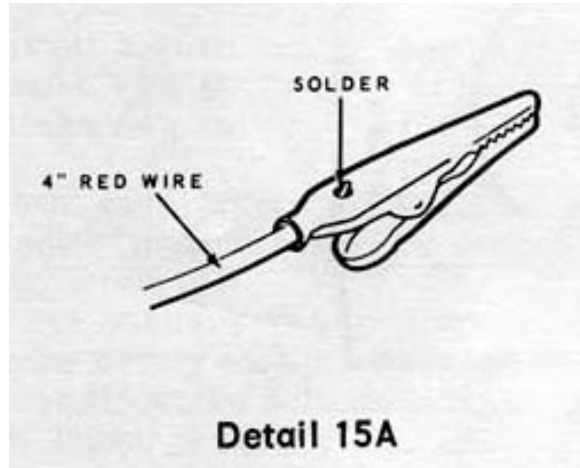

Carefully examine all connections to be sure that they are properly made and soldered.

Now proceed to the knob installation steps that follow.

Knob Installation

The knobs supplied with this kit use knob bushings that provide positive action without the use of setscrews.

In the following steps, you will install a knob on each switch and control shaft as shown in detail 17A. Perform these steps carefully, since it is difficult to remove a knob from a bushing once it is fully inserted.

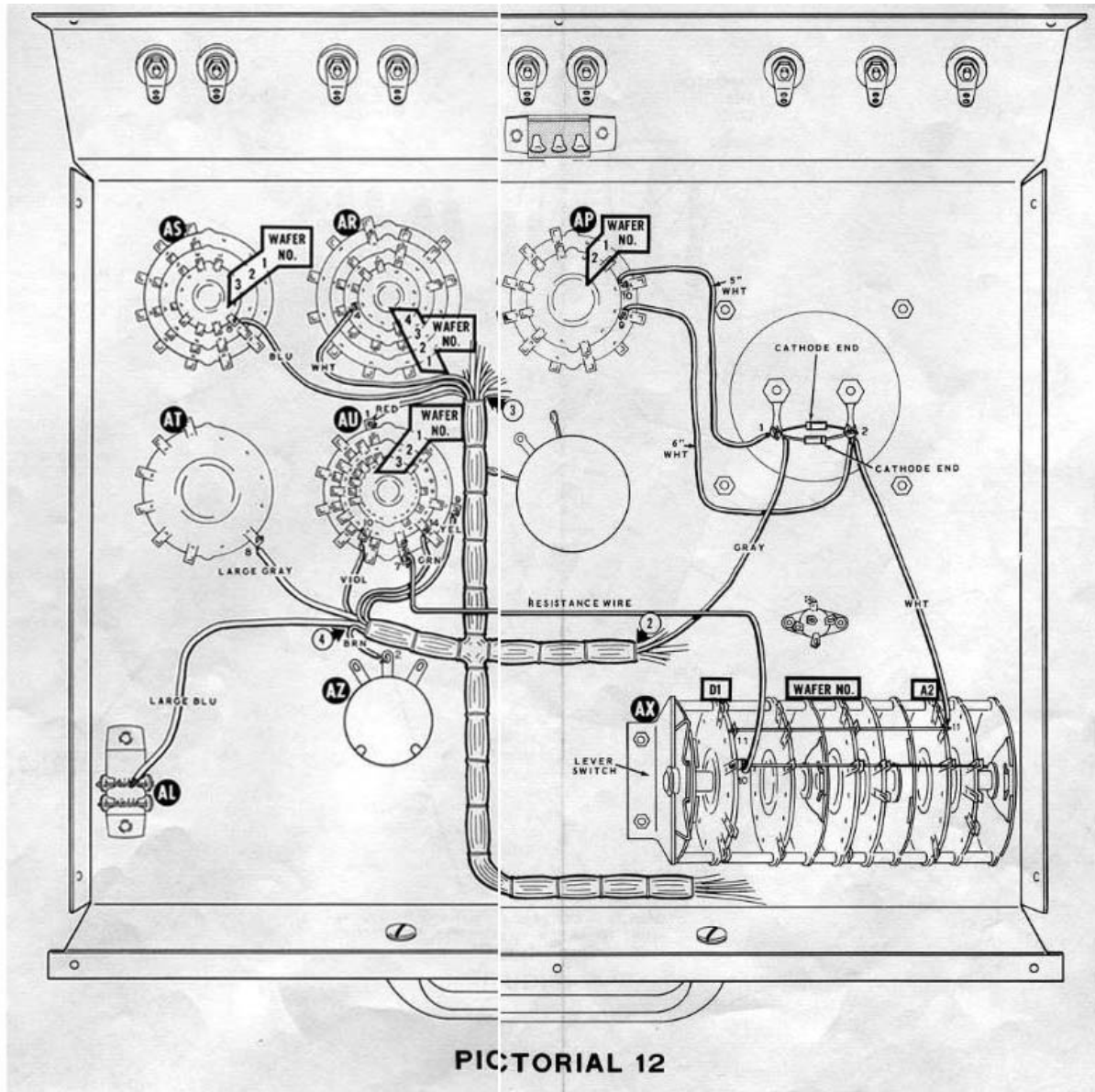

Refer to Pictorial 17 for the locations of the switch and control shafts.

- () Place a knob bushing on each of the switch and control shafts; the spring tab on the bushing should face outward.
- () Turn each control and switch shaft to its full counter-clockwise position.

- () Press a knob firmly onto only the BIAS control bushing with the pointer at the 7 o'clock position.
- () With the bushing installed on it, remove the BIAS knob. Then press the knob bushing firmly into the knob with the handle of a screwdriver.

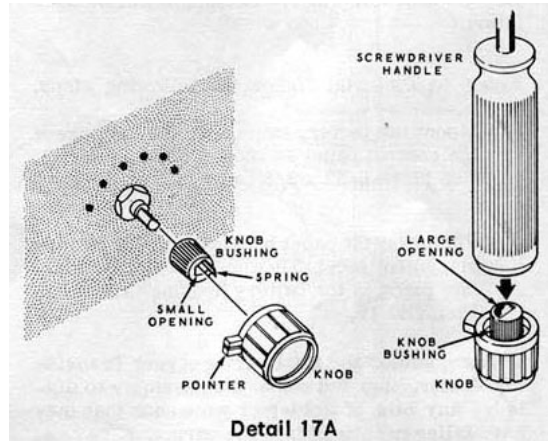

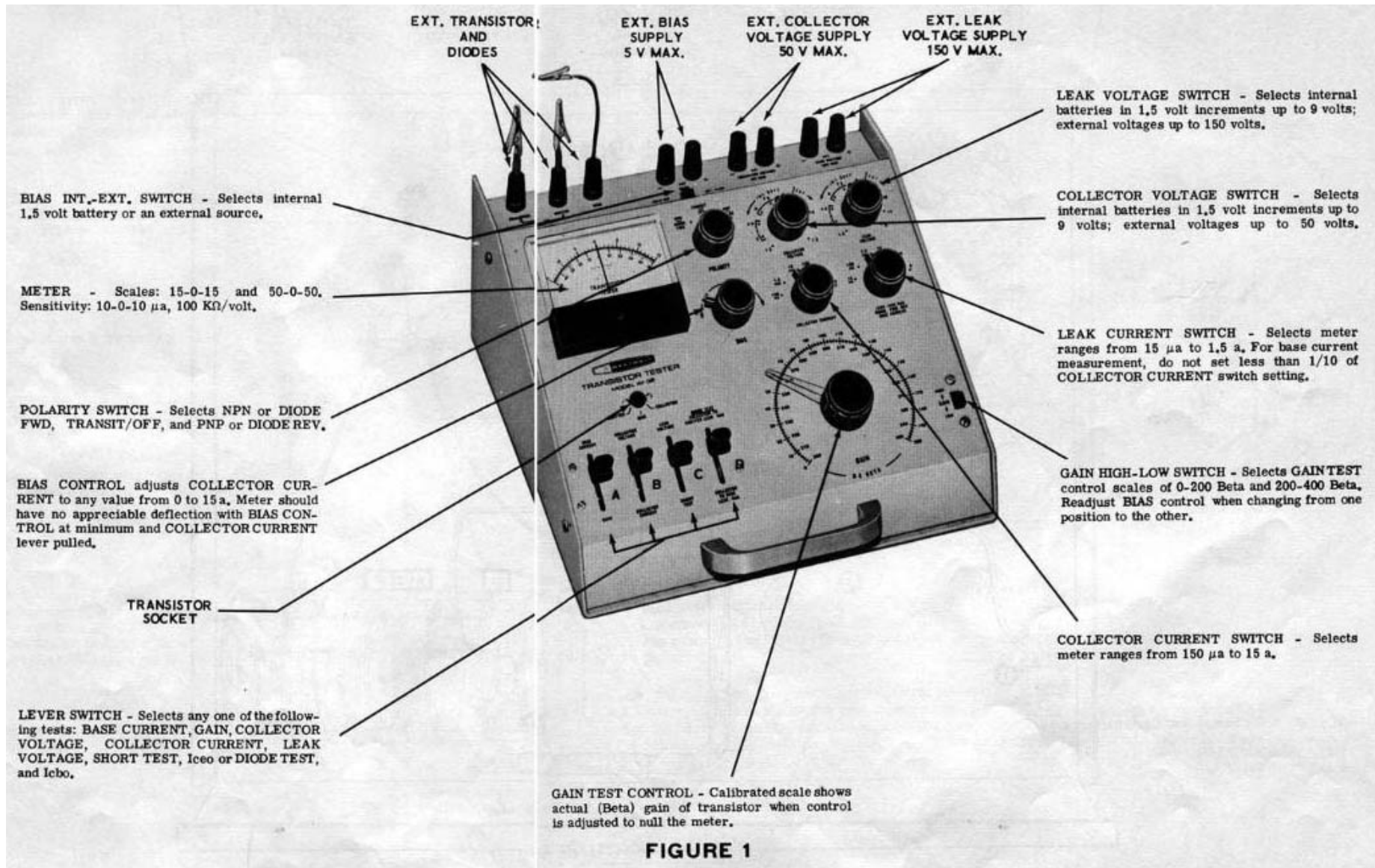

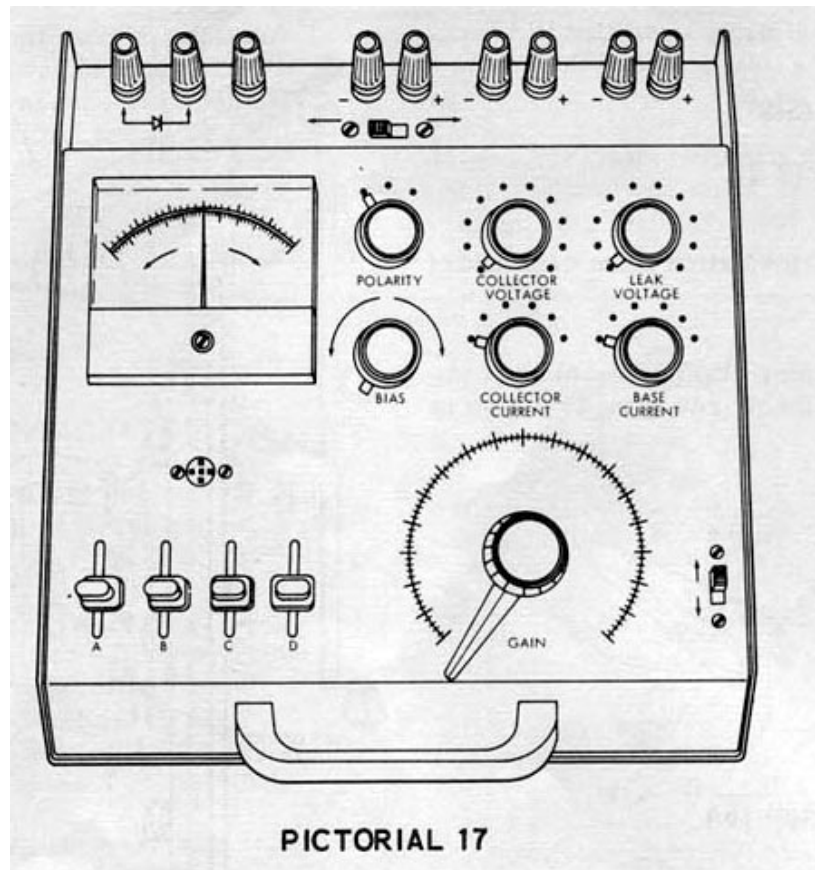

PICTORIAL 17

- () Reinstall the BIAS knob.

Note: The Gain control knob will not be installed until after the adjustments have been made in a later section.

- () Install a knob lightly on each of the switch shafts with the pointer at the full counter-clockwise position.
- () Turn each knob clockwise to see if the pointer lines up with each switch marking.
- () If the pointers line up properly, press the knobs firmly onto the bushings and then remove the knobs with their bushings. Press the bushings firmly into the knobs with a screwdriver handle, then reinstall the knobs. If a pointer does not line up properly, perform the next three steps.

Note: It is not necessary to perform the next three steps if the pointer lines up properly at each switch marking.

1. () Turn the knob pointer to a mid-position marking on the panel.
2. () Remove the knob from the bushing and turn it slightly to line up the pointer with the mid position marking.
3. () Press the knob slightly onto the knob bushing. Then turn the knob to each switch position and recheck the pointer alignment. If more than a slight error is noticed at either end position, repeat these three steps.

- () When the pointer lines up properly with the switch positions, remove the knob and bushing together and press the bushing firmly into the knob with a screwdriver handle. Then replace the knob on the shaft.
- () Install the four lever knobs on the lever shafts A, B, C, and D.

Battery Installation.

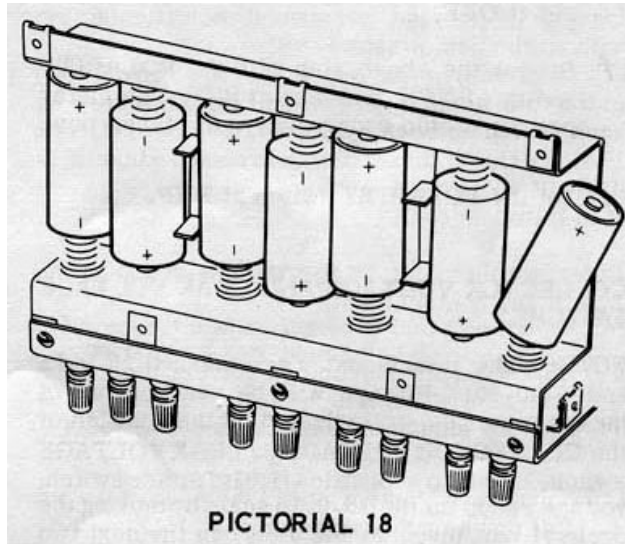

Note: Before you install batteries in the Transistor Tester, be sure the **Polarity** switch is in the **Transit / Off** position.

- () Refer to Pictorial 18 and install seven D-cell batteries in the battery housing. As you install each battery, press the negative (-) end firmly against the battery contact spring. Then slip the positive (+) end into place against the positive contact screw head.

Batteries can be replaced in the same manner should they become weak through extended use. After the Transistor Tester is fully assembled, it will only be necessary to remove the rear cover to expose the batteries.

Initial Tests and Adjustments

The tests you will perform in this section of the Manual will verify that the Transistor Tester was properly assembled and wired. The adjustments will calibrate the Gain control knob for accurate gain measurements. See Figure 1 (fold-out from page 28) for location of these switches and controls.

If the Indicated results are not obtained in any of these tests, refer to the In Case of Difficulty section on Page 41

Initial Tests.

- () Set the Polarity switch in the **Transit/Off** position.
- () Set all other rotary switches and controls at their full counter-clockwise positions.

Polarity Switch

- () Pick up and shake the Transistor Tester from side to side to make the meter pointer swing both side of zero. The pointer movement should be well damped (hard to swing from zero) when the **Polarity** switch is set at **Off**.
- () Repeat the above step with the **Polarity** switch set at NPN, and then at PNP. The meter should swing much more freely now.
- () Set the polarity switch at PNP.

Collector Voltage and Leak Voltage Switches

Note: The meter scales are marked 15-0-15 and 50-0-50. Voltage will be read on one of the two scales, as indicate by the position of the **Collector Voltage** or **Leak Voltage** switch. In the first position (1.5) of either switch, voltage reads on the 15-0-15 scale by moving the decimal point one place to the left. In the next two switch positions (3 and 4.5), the 50-0-50 scale is used with the decimal moved one place to the left. For the next three switch positions, voltage is read directly on the 15 scale.

- () Raise lever switch B to the **Collector Voltage** position. The meter pointer should deflect to the right and indicate 1.5 volts, or slightly higher if fresh batteries were installed.
- () Change the **Polarity** switch to NPN and repeat the previous step. The pointer should deflect to the left and indicate 1.5 volts.
- () Turn the **Collector Voltage** switch to 3, 4, 5, 6, 7.5 and 9 repeating the preceding two steps at each position. The meter should indicate the same voltage as marked for each position of the switch.
- () Repeat the preceding three steps, using the **Leak Voltage** switch and raising lever switch C to the **Leak Voltage** position.

Note: The meter will not deflect when lever switches B or C are raised if the corresponding **Collector Voltage** or **Leak Voltage** switch is in any **Ext** position during these tests.

Bias Control

- () Temporarily connect a wire between the **Emitter** and **Base** binding posts.
- () Set the switches and controls as follows:

Polarity Switch	to	PNP
Collector Current switch	to	150 ma.
Leak Current switch	to	15 ma.
Gain switch	to	Low.
Bias switch	to	Int.
Bias Control	to	Full counter-clockwise

- () Raise lever switch A to **Base Current** and advance the **Bias** control about 1/3 rotation. The meter pointer should deflect about two divisions to the right on the

0-15 scale. While holding lever switch A up, change the Bias switch to **Ext** and the meter should return to zero.

Collector Current Lever Switch B

- () Remove the shorting wire from between the **Emitter** and **Base** binding posts. Then connect the wire between the **Collector** and **Emitter** binding posts.
- () Set the following switches to the position indicated:

Polarity to PNP
Collector Voltage to Int 1.5.
Collector Current to 15 a.
- () Press lever switch B to the **Collector Current** position. The meter should deflect slightly.
- () Change the **Collector Current** switch to 1.5 a and again press lever B. The pointer should now deflect to full scale.

Short Test Lever Switch C.

- () Leave the shorting wire connected between the **Collector** and **Emitter** binding posts. Leave the switches set as for the previous test.
- () Press lever switch C to **Short Test**. The meter should deflect.
- () Remove the shorting wire from the binding post and again press lever switch C. The meter should remain at zero.

Collector to Base Leak Switch D.

- () Connect a shorting wire between the **Base** and **Collector** binding posts.
- () Set the **Leak Voltage** switch to Int. 1.5 and the **Leak Current** switch to 1.5 a.
- () Press the lever switch D to **Collector to Base Leak** – I_{CBO} . The meter should deflect slightly beyond full scale.

Gain Switch, High-Low.

- () Connect a shorting wire between the **Base** and **Emitter** binding posts.
- () Set the switches and controls as follows:

Polarity Switch	PNP
Collector Current switch	15 ma.
Gain switch	Low
Bias Control	Fully counter-clockwise
Bias Switch	Int.
Gain Control	½ rotation

- () Press lever switch A to **Gain** and adjust the **Bias** control until the meter pointer deflects slightly to the left of zero.

- () While holding lever switch A down, change the **Gain** switch to **High**. The pointer deflection should now be slightly greater.

If the proper results were obtained in all of the Initial Tests, proceed with the adjustment section that follows.

Adjustments

Meter Zero Adjustment.

- () Turn the **Polarity** switch to the **Transit/Off** position.
- () Lightly tap the meter face with your finger and note whether the pointer is directly over zero.
- () Turn the screw on the meter face slowly in either direction, while tapping the meter face with a finger, to place the pointer directly over zero.

Gain Control Adjustment.

- () Connect a shorting wire between the **Emitter** and **Base** binding posts.
- () Set the switches and controls as follows.

Polarity Switch	PNP
Collector Voltage switch	1.5
Collector Current switch	15 ma
Gain switch	Low
Bias Control	Fully counter-clockwise
Gain Control	Fully counter-clockwise

- () Temporarily install the large pointer knob lightly on the Gain control knob bushing, with the pointer over 0/200. Then turn the knob clockwise to 20.
- () Press lever A to **Gain** and turn the **Bias** control clockwise until the meter indicates 5 to the left on the 15 scale.
- () Turn the **Gain** control fully counter-clockwise. Then hold down lever switch A and slowly turn the gain control clockwise until the meter pointer just starts to deflect.
- () Note whether the **Gain** control pointer is directly over the 0/200 mark on the dial. If not, carefully remove the knob from the knob bushing and reinstall it. Be sure you do not turn the shaft, and that the 0/200 mark is where the meter pointer just starts to deflect.
- () Press the knob firmly onto the bushing.

Note: If the zero position of the Gain control knob pointer is the starting point of meter pointer deflection, proceed to the Operational Check instructions. Otherwise perform the following steps.

- () Remove the **Gain** control knob from its shaft, then loosen the control nut on the panel.
- () Replace the knob on the control shaft.
- () While holding down lever switch A, turn the **Gain** control knob until the meter pointer just starts to deflect.
- () Reach under the control panel and carefully turn the body of the **Gain** control until the knob pointer is directly over zero.
- () While holding the body of the **Gain** control firmly against the inside of the panel, remove the knob and tighten the control nut.
- () Replace the **Gain** control knob and recheck the zero position with the meter deflection. Repeat the previous five steps if necessary.

This completes the test and adjustments of the Transistor Tester.

Operational Check.

This section of the manual will give you an additional check to be sure your Transistor Tester is operating properly before you install it in the cabinet.

Two or three transistor that are known to be good will be required for this check.

- () Insert the leads of a test transistor on the panel. Use the three binding posts at the top left-hand side if the transistor leads do not fit the socket. See Figure 2.
- () Set the control and switches as follows:

Bias control	Full counter-clockwise
Bias switch	Int.
Polarity switch	To type of transistor (PNP or NPN)
Collector Voltage switch	1.5 volts Int.
Leak Voltage switch	9 volts Int.
Collector Current switch	15 ma
Leak Current switch	1.5 ma
Gain switch	Low.

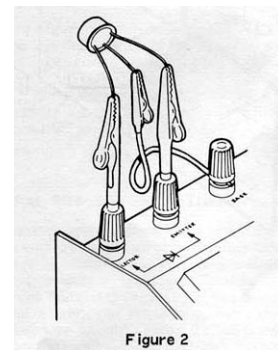

Figure 2

- () Press lever switch C to **Short Test**. If the transistor is not shorted, the meter pointer will not deflect from zero. If the pointer does deflect, try another transistor.
- () Press lever switch B to **Collector Current** and slowly advance the **Bias** control. Notice that the meter indicates higher collector current as the bias is increased if the transistor is good. Now adjust the **Bias** control until the meter indicates 5 ma of collector current.
- () Check the collector voltage by raising lever switch B to Collector Voltage. The meter should read approximately 1.5 volts.

- () Press lever switch A to **Gain** and rotate the **Gain** control until the meter indicates zero. The knob pointer will read upscale to 30 or more depending on the particular transistor being tested.
- () Raise lever switch A to **Base Current**. The base current range is set with the **Leak Current** switch. This setting must not be less than 1/10 of the **Collector Current** switch setting. Otherwise, the base current would be reduced.
- () Raise lever switch C to **Leak Voltage**. The meter should indicate 9 volts.
- () Raise lever switch D to **Collector To Emitter Leak** - I_{CBO} and note the leakage indicated on the meter. If the meter pointer goes off scale, increase the **Leak Current** switch setting.
- () Press lever switch D to **Collector To Base Leak** - I_{CBO} and read the leakage on the meter. Change the setting of the **Leak Current** switch, if necessary. Note that I_{CBO} is much smaller than I_{CEO} .
- () Place the **Polarity** switch in the **Transit/Off** position. The preceding steps provided an operational check of your Transistor Tester. The procedure and result should have been typical for a good transistor of the type tested. Detailed information on complete use of the Tester will be found in the Operation section.

Now that you are sure the Tester will operate properly, proceed to the Final Assembly instructions that follow.

Final Assembly.

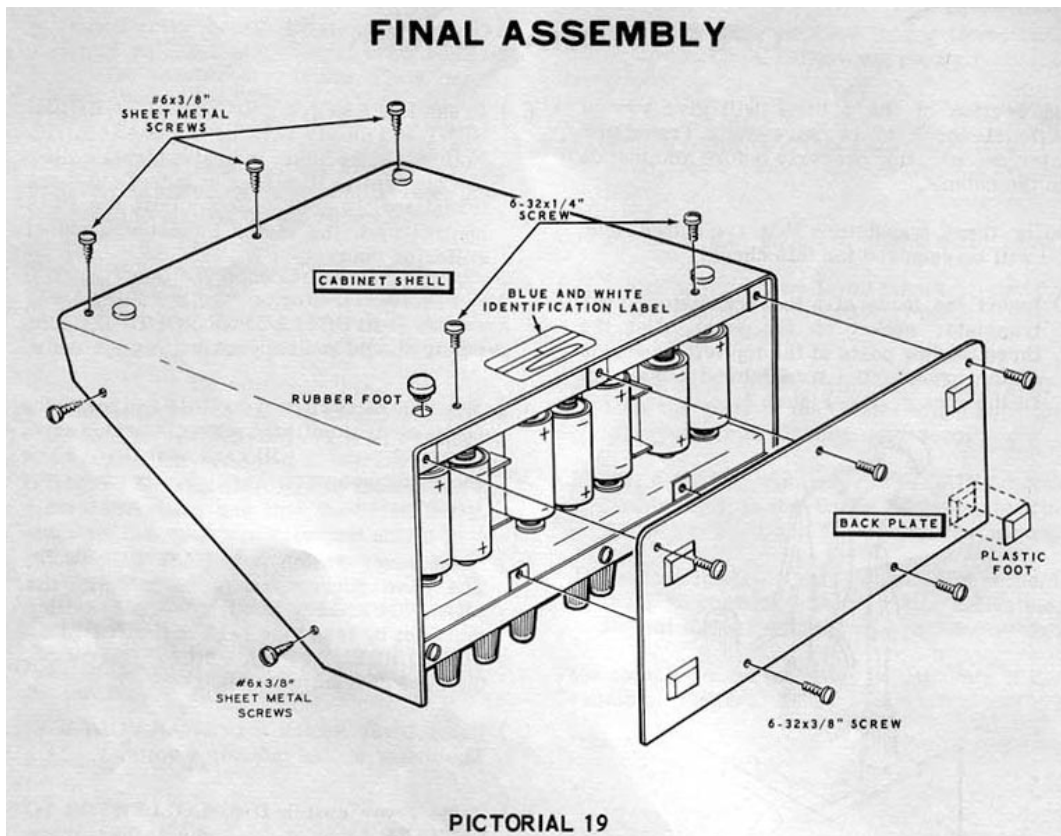

Refer to Pictorial 19 for the following steps.

- () Install a rubber foot in each of the four mounting holes in the bottom of the cabinet shell. Use a small screwdriver to pull the small end of the foot through the hole.
- () Install the unit in the cabinet shell, using three #6 sheet metal screws and two 6-32 x 1/4" screws on the bottom of the cabinet. Tighten securely.
- () Insert four #6 x 3/8" sheet metal screws in the sides of the cabinet. Do not tighten.
- () Install a plastic foot in each corner of the back plate. First remove the protective backing from the foot, and then press the foot firmly into position.
- () Install the back plate, using five 6-32 x 3/8" screws. Do not tighten.
- () Make sure the back plate is flush with the top panel and tighten the five screws on the back of the unit.
- () Now tighten the two screws on each side of the cabinet.
- () Carefully peel away the backing paper from the blue and white identification label. Then press the label onto the bottom of the cabinet shell. Be sure to refer to the numbers on this label in any communications you have with the Heath Company about this kit.

Your Transistor Tester can now be put into service.

Operation

Although you made a "rough test" of a transistor while performing the Operational Check, you will need a thorough understanding of your Transistor Tester, and a knowledge of how to interpret its meter readings to accurately test the quality of transistors. Read the following pages carefully.

This Tester measures the DC Beta (gain) characteristic of transistors, a characteristic that will even vary between transistors of the same type. This DC Beta test will give you the actual operating characteristics of a transistor, and not merely give you a "bad" or a "good" rating.

Refer to Figure 1 (fold-out from Page 28) for the location and description of the controls, switches, and connections on the Transistor Tester.

Note: When carrying or moving the Tester, the Polarity switch should be in the **Transit/Off** position to damp movement of the meter pointer.

General Transistor Testing

A transistor specification sheet or rating chart will be required for testing transistors to manufacturers specifications. This data is contained in most standard transistor manuals. (See Reference Material, Page 41.) If you do not have data for a particular

transistor, refer ahead to the procedure titled "Testing Transistors With Unknown Ratings."

Caution: Do not test FET or SCR types with this Transistor Tester. Field effect transistors (FET) or silicon controlled rectifiers (SCR) require special equipment for testing.

Set up the conditions for the transistor to be tested by setting the following switches to the desired parameters, as listed in the specification sheet or manual:

Collector Voltage;
Leak Voltage;
Collector Current;
Leak Current;
Polarity (NPN or PNP).

Set the BIAS control fully counter-clockwise. Then insert the transistor leads into the socket, or connect the leads to the proper terminal posts. Refer to a basing chart to identify the emitter, base, and collector leads and be sure to connect the transistor leads properly.

Note: The following tests are momentary. Do not hold a lever switch up or down longer than necessary to obtain a meter reading. Never move more than one lever switch at a time.

Press lever switch C for **Short Test**. A shorted transistor will cause a reading of 4 or more on the 15 scale of the meter.

Raise lever switch D to the **Collector To Emitter Leak** - I_{CE0} position. Read the leakage current on the meter. Change the **Leak Current** switch position if the meter reads off scale.

Press lever switch D to the **Collector to Base Leak** - I_{CBO} position and read the leakage on the meter. Note that I_{CBO} is much lower than I_{CE0} .

Press lever switch B to **Collector Current** and adjust the **Bias** control for proper collector current.

Raise lever switch B to **Collector Voltage** and read the meter to see that proper voltage is applied.

Press lever switch A to **Gain** and adjust the **Gain** control until the meter reads zero.

Read the gain indicated by the pointer on the **Gain** control knob.

Note: Two **Gain** control ranges are provided. The 0-200 outer range is used when the **Gain** switch is in the **Low** position. The **200-400** inner range is used when the **Gain** switch is in the **High** position. The **Bias** control must be readjusted to provide correct collector current when using either the **High** or **Low** positions of the **Gain** switch.

Testing Transistors With Unknown Ratings

Set the switches and control as follows for each of the tests in this section.

Polarity Switch - PNP.

Collector Voltage Switch	-	1.5 int.
Collector Current Switch	-	15 ma.
Leak Voltage Switch	-	9 int.
Bias Control	-	full counter-clockwise.

Insert the transistor leads in the transistor socket, or connect them to the proper binding posts at the top of the panel.

Short Test

Press lever switch C to **Short Test**. The meter will indicate 4 or more on the 15 scale if the transistor is shorted. Do not make any further tests on a shorted transistor.

Testing for PNP or NPN

Press lever switch B to **Collector Current**, if the meter pointer does not deflect, advance the bias control to see if a collector current is obtained. If the meter pointer now deflects to the right, the transistor is a PNP type. Leave the polarity switch at PNP.

If the meter pointer does deflect with the bias control fully counter-clockwise when lever switch B is pressed, the transistor is probably an NPN type. Turn the bias control clockwise while holding down lever switch B. If the meter pointer moves toward zero as the bias control is advanced, it confirms that the transistor is an NPN type. Then change the polarity switch to NPN and the collector current should increase normally as the bias control is advanced.

Testing Small Transistors

After you have determined whether the transistor is NPN or PNP, be sure the **Polarity** switch is set accordingly.

Press lever switch B to **Collector Current** and advance the bias control, if the collector current increases as the bias control is advanced, the transistor is conducting.

As a final check, press lever switch D to I_{CBO} . Leakage current should not be more than $25 \mu a$. Raise lever switch D to I_{CEO} and note that this leakage current is much higher than I_{CBO} .

Testing power transistors

Change the collector current switch to 1.5 a. Press lever switch B to **Collector Current** and advance the bias control. If the collector current increases as the bias control is advanced, the transistor can be assumed to be good. As a final check, press lever switch D to I_{CBO} . The leakage current should not be over 5 ma.

Matching Transistors for Gain and Leakage

Set up test as for transistor testing. Using identical bias control and leak voltage switch settings, insert each transistor to be checked into the transistor socket and determine gain and leakage. Then separate them into common groups.

Production Go No-Go Tests

PNP Transistors

Set up the specified test conditions. Check for shorts; then check for leakage. Each transistor must show less than the maximum allowable leakage for the particular production application.

For checking gain, set up the proper bias condition and set the gain control for minimum allowable gain. With the gain lever pressed, each transistor having a gain higher than the minimum allowable (preset) will deflect the meter to the right. Any transistor having less gain will deflect the meter to the left.

NPN Transistors

Use the same procedure as described above, except NPN transistors having a gain higher than the minimum allowable will deflect the meter to the left. NPN transistors having less gain will deflect the meter to the right.

DC Current gain (h_{fe})

Note: the base current switch setting should not be more than one range lower than the collector current switch setting. If this is not done, the meter resistance will reduce the original collector current setting.

DC current gain is defined as collector current (I_c) divided by base current (I_B); that is,

$$\beta_{dc} = h_{fe} = \frac{I_c}{I_B} ; \alpha = \frac{\beta_{dc}}{\beta_{dc} + 1}$$

DC current gain, beta and alpha, is read directly from the calibrated dial under the gain control pointer. This gain may be found using the instructions under general transistor testing.

AC Current Gain (h_{fe})

AC current gain equals $\frac{\Delta I_c}{\Delta I_B} \Big|_{E_c \text{ constant}}$

or $\frac{I_{c1} - I_{c2}}{I_{B1} - I_{B2}}$ at the same E_c .

AC current gain is defined as: the change in collector current divided by the change in base current that produced the change in collector current, with collector voltage held constant.

Set the **Polarity, Collector Voltage, Collector Current,** and **Leak Current** switches to the desired positions, depending on the type of transistor to be checked.

Press the **Collector Current** lever and adjust the bias control to the desired collector current (I_{c1}). Raise the base current lever and read base current (I_{B1}) on the meter.

Now press the collector current lever and adjust the bias to a lower collector current, say 25%. This is I_{c2} . Raise the base current lever and read I_{B2} in the meter.

Using the values determined above, calculate the ac current gain.

DC Transconductance (g_{fe})

DC transconductance is defined as collector current (I_c) divided by base voltage (E_B);

that is $g_{FE} = \frac{I_c}{E_B}$.

To find g_{FE} , set up a given bias condition and, with an external voltmeter, measure base to emitter voltage at the external transistor terminals. Then use the above formula.

AC Transconductance (g_{FE})

AC transconductance is defined as a change in base voltage (ΔE_B) that will produce a change in collector current (ΔI_c), with collector voltage (E_c) held constant; that is,

$$g_{FE} = \frac{\Delta I_c}{\Delta E_B} \Big|_{E_c \text{ constant}}, \text{ or } \frac{I_{c1} - I_{c2}}{E_{B1} - E_{B2}} \Big|_{E_c \text{ constant}}$$

To find g_{FE} , set up a given bias condition, press the **Collector Current** lever and adjust the **Bias** control. Read collector current I_{c1} on the meter. With an external voltmeter measure base to emitter voltage E_{B1} at the external transistor terminals. Now press the collector current lever, reduce the bias, and read I_{c2} on the meter. Read E_{B2} on an external voltmeter.

Calculate g_{FE} by $= \frac{I_{c1} - I_{c2}}{E_{B1} - E_{B2}}$

DC Base Resistance (R_B)

DC base resistance is defined as base voltage (E_B) divided by base current (I_B); that is,

$$R_B = \frac{E_B}{I_B}$$

Set up a given bias condition, press the **Collector Current** lever, and adjust the **Bias** control. Raise the **Base Current** lever and read I_B on the meter. With a voltmeter connected between the **Base** and **Emitter** transistor terminals, read base voltage E_B .

AC Base Resistance

AC base resistance is defined as the change in base voltage (E_B) divided by the change in base current (I_B) with collector voltage (E_c) held constant; that is,

$$\frac{\Delta E_B}{\Delta I_B} \Big|_{E_c \text{ constant}}$$

To find AC base resistance, set up a given bias condition, press the **Collector Current** lever and adjust the bias control. Raise the **Base Current** lever and read I_{B1} . With a voltmeter connected between **Base** and **Emitter** external transistor terminals, read base voltage E_{B1} . Now press the collector current lever and reduce the bias. Raise the base current lever and read I_{B2} . Read E_{B2} on external voltmeter.

Using the values just found, calculate ac base resistance as follows:

$$\frac{E_{B1} - E_{B2}}{I_{B1} - I_{B2}}$$

DC Collector Resistance

DC collector resistance is defined as collector voltage E_c divided by collector current I_c ; that is, $R_c = \frac{E_c}{I_c}$.

To find DC collector resistance, set up a given bias condition, press the **Collector Current** lever and adjust the **Bias** control. Read collector current I_c . Raise the **Collector Voltage** lever and read collector voltage E_c .

AC collector resistance

AC collector resistance is defined as a change in collector voltage (E_c) divided by the change in collector current (I_c) with the base current (I_B) held constant; that is,

$$\frac{\Delta E_c}{\Delta I_c} \Big|_{I_B \text{ constant}}$$

To find AC collector resistance, set up a low collector voltage condition. Press the **Collector Current** lever and adjust the **Bias** control. Read collector current I_{c2} . Now raise the **Collector Voltage** lever to read collector voltage E_{c2} .

Increase the **Collector Voltage** switch setting, use the same bias setting as above, and read E_{c1} . Now push the collector current lever and read I_{c1} .

Using the values just found, calculate AC collector resistance as follows: $\frac{E_{c1} - E_{c2}}{I_{c1} - I_{c2}}$

Transistor Leakage Tests

I_{CBO} = collector to base leakage with the emitter open.

Adjust the **Leak Voltage** switch to the specified voltage, and set the **Leak Current** switch to the proper meter range. Press the I_{CBO} lever and read leakage current directly.

I_{CEO} = collector to emitter leakage with the base open.

Adjust the **Leak Voltage** switch to the specified voltage, and set the **Leak Current** switch to the proper meter range. Raise the I_{CEO} lever and read leakage current directly.

I_{CES} = collector to emitter leakage with base shorted to the emitter.

Connect a shorting wire between the **Base** and **Emitter** binding posts. Then read I_{CES} on the meter, using the same procedure as outlined above for I_{CEO} .

I_{CER} = collector to emitter leakage with a specified resistance connected between the base and emitter.

Connect the specified resistance between **Base** and **Emitter** binding posts. Then read I_{CER} on the meter, using the procedure outlined for I_{CEO} .

I_{CERV} , I_{CEX} collector to emitter leakage with specified reverse bias battery and resistance in series between the base and emitter.

Connect the specified reverse battery and resistance between the **Base** and **Emitter** binding posts. Now read I_{CERV} or I_{CEX} on the meter, using the procedure outlined above for I_{CEO} .

Diode Testing

Reverse Current

Set the **Leak Voltage** switch to the proper value and set the **Leak Current** switch to the proper meter range. Place the **Polarity** switch in the **Diode Rev** position. Press the **Short** lever to see if the diode is shorted. If the diode is not shorted, raise the diode lever and read the reverse (leakage) current on the meter.

Forward Current

Warning: Always connect a resistor in series with the diode before checking forward current. Without a series resistor, too much current will flow, possibly damaging the diode.

Example: A silicon diode normally drops approximately 0.7 volt. If the 1.5 volt supply is used, a series resistor must be used to drop the other 0.8 volt.

$I = 500 \text{ ma}$

$$E = 0.8 \text{ V} \quad R_s = \frac{E}{I} = \frac{0.8}{0.5} = 1.6 \Omega$$

Here a 2Ω resistor will prevent excessive current from damaging the diode under test.

The series resistor may be left connected when checking **Reverse Current**. The series resistance is normally a very small resistance compared to the high reverse-current resistance of the diode.

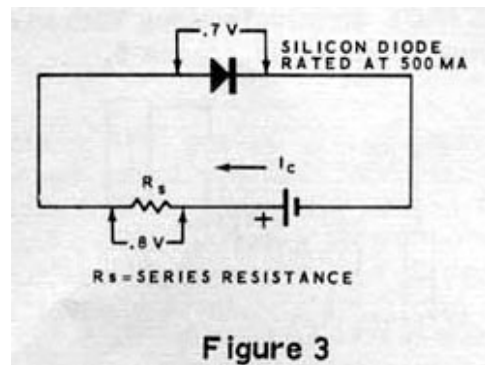

Connect the diode to be tested and the predetermined series resistor to the external transistor terminals, cathode to the **Emitter** and diode anode to the **Collector** (diode terminals). Set the **Leak Voltage** switch to the proper value and the **Leak Current** switch to the proper meter range. Place the **Polarity** switch in the **Diode Fwd** position. Raise the **Diode** lever and read forward current on the meter.

Other types of diodes may also be tested as just described.

External bias voltage terminals

The external bias terminals should be used when continuous power transistor testing is required. The external bias supply may be a battery or any high-current, low-voltage unit, such as a battery eliminator.

Connect the external bias (DC power) supply leads to the external bias terminals; the positive lead to positive (+) terminal and the negative lead to negative (-) terminal.

Set the **Bias** switch to the **Ext** position. The internal bias control is used to set the desired amount of bias. **Note:** a maximum of 5 volts may be applied to these terminals.

External Collector Voltage Terminals

The external collector voltage terminals should be used when continuous power transistor testing is required. The external collector voltage power supply may be any high-current unit, such as a battery eliminator.

Connect the external DC power supply to external **Collector Voltage** terminals; the positive lead from the power supply connects to the positive (+) terminal and the negative lead to the negative (-) terminal.

Adjust the **Collector Voltage** switch to the desired **Ext** voltage range. Now set the power supply for the desired collector voltage. **Note:** a maximum of 50 volts may be applied to these terminals.

External Leak Voltage Terminals

The external **Leak Voltage** terminals must be used when higher leak voltages are required than are available from the internal battery supply. The external leak voltage power supply may be any high-voltage supply such as a laboratory dc power supply.

Connect the external dc power supply leads to the external **Leak Voltage** terminals, the positive lead to the positive (+) terminal and the negative lead to the negative (-) terminal.

Adjust the **Leak Voltage** switch to the proper **Ext** voltage range. Now set the power supply for the desired **Leak Voltage**. **Note:** a maximum of 150 volts may be applied to these terminals.

Checking Current Ranges

Ext. Transistor Terminals

Connect an external DC ammeter between the **Collector** and **Emitter** external terminals. The positive (+) side goes to the emitter with the polarity switch in the PNP position. Connect resistance R_x in series with the ammeter as shown in figure 4.

Before calculating the size of resistor R_x decide on the current range to be checked, and what voltage it will be checked at.

For example:

Current range to be checked - 150 milliamperes.
$$R_x = \frac{E}{I} = \frac{1.5}{0.15} = 10\Omega$$

Collector voltage used -1.5 volts.

In this case, a 10Ω resistor is used as R_x to limit the current to 150 milliamperes.

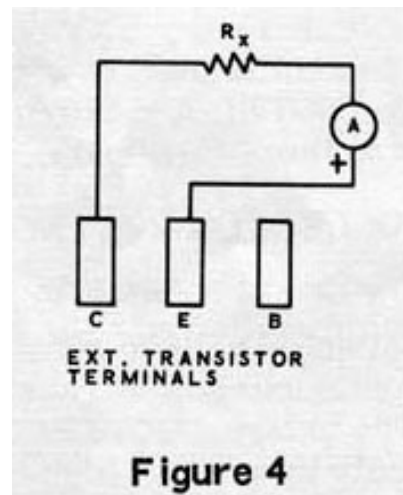

Set the **Polarity** switch to PNP and set the **Collector Voltage** switch to 1.5 volts. Now press the **Collector Current** lever and compare the current indicated on the ammeter with the current indicated by the meter on the Transistor Checker. If an appreciable difference is found between the two readings, and if you are certain of the accuracy of the external ammeter, the meter and shunt resistors of your checker should be checked.

This same procedure may be used to check the other current ranges.

Checking Voltage Ranges

Connect an external DC voltmeter between the external **Collector** and **Emitter** terminals. The positive (+) side of the meter goes to the **Emitter** terminal.

Set the **Polarity** switch to PNP and set the **Collector Voltage** switch to the internal voltage range to be checked. Raise the **Collector Voltage** lever and compare the **Leak** voltage readings on the two meters. If an appreciable difference is found between the two readings, check the meter and multiplier resistors of your transistor checker.

To check the higher external ranges, connect an external power supply to the **External Leak Voltage** terminals along with an external voltmeter as shown in figure 5.

Set the **Leak Voltage** switch to the desired external range. Then raise the **Leak Voltage** lever to read the **Leak** voltage and compare the two meter readings.

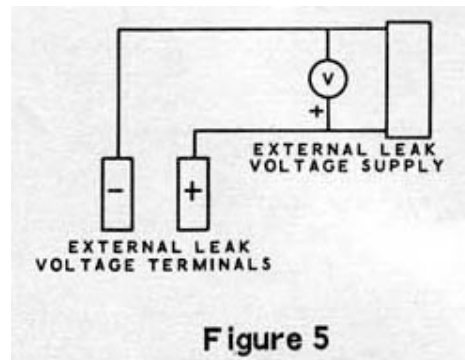

Cleaning the Cabinet

The cabinet of this instrument may be cleaned with a mild soap and water solution, and a soft brush or towel-like cloth. Do not allow any moisture to get inside the equipment.

Reference Material

Several good semiconductor handbooks and manuals are available. These publications list the design characteristics of transistors or diodes, and also contain much helpful information on semiconductor theory, circuits, and applications some of these publications are listed here.

Transistor Manual
RCA Transistor Manual
Power Transistor Handbook
Silicon Zener Diode and Rectifier Handbook
Transistor Circuit Analysis and Design by Corning
Practical Transistor Theory by E. Patrick Wiesner

General Electric Co.
Radio Corporation of America.
Motorola, Inc.
Motorola, Inc.
Prentice Hall
Howard W. Sams PTW-1.

Manufacturers specification sheets of particular transistor and diode types. - write directly to manufacturer involved.

In Case of Difficulty

1. Recheck the wiring. Trace each lead in colored pencil on the pictorial as it is checked. It is frequently helpful to have a friend check your work. Someone who is not familiar with the unit may notice something consistently overlooked by the builder.

About 90% of the kits that are returned for repair do not function properly due to poor connections and soldering. Therefore, many troubles can be eliminated by reheating all connections to make sure that they are soldered as described in the soldering section of the kit builders guide.

3. Check the values of the component parts. Be sure that the proper part has been wired into the circuit, as shown in the pictorial diagrams and as called out in the wiring instructions.
4. Check for bits of solder, wire ends or other foreign matter which may be lodged in the wiring beneath the panel.
5. A review of the circuit description may also prove helpful in indicating where to look for trouble.
6. Make sure the batteries are not run down. If necessary, install a fresh set of batteries.
7. Repeating the Instrument Checkout procedure may be helpful in pinpointing the problem.

Note: in an extreme case where you are unable to resolve a difficulty, refer to the service and warranty sections of the "kit builders guide" and to the "factory repair service" information on page 43 of this manual.

Battery Replacement

Replace only those batteries that check weak, since some of the batteries are used more than others. Note that the batteries may be replaced without taking the unit out of the cabinet shell, by removing the back plate.

Troubleshooting chart

if one of the switches or controls does not respond properly during the initial test procedure, the chart below will show where the difficulty might be found. Refer to the correct switch or control and check the wiring of the components listed under "possible source of difficulty." Refer to the pictorials listed

Control or Switch	Possible Source of Difficulty
a. Polarity switch	Polarity switch and meter. See pictorial 10.
b. Collector and Leak Voltage switches.	Batteries, battery housing, meter; Polarity, Collector, and Leak Voltage switches. Lever switch wafers b and c. See pictorials 1, 2, 4, 6, 7, 9, and 10.
c. Bias control.	Batteries, battery housing, meter; bias, Polarity, Collector,

- and Leak Current switches; Lever switch wafer a. Bias and Gain controls. External transistor terminals. See pictorials 3, 4, 8, 9, and 10.
- d. Collector Current Lever switch B. Batteries, battery housing, meter; Polarity, Collector Voltage, and Collector Current switches; Lever switch wafer b. External transistor terminals. See pictorials 2, 3, 4, 6, 8, 9, and 10.
 - e. Short Test Lever Switch C. Batteries, battery housing, meter; Polarity, Collector Voltage, and Collector Current switches; Lever switch wafer c. External transistor terminals. See pictorial 2, 3, 4, 6, 7, 8, 9, and 10.
 - f. Leak Current Lever Switch D. Batteries, battery housing, meter; Polarity, Leak Voltage, and Leak Current switches; Lever switch wafer d. External transistor terminals. See pictorials 1, 4, 6, 7, 8, 9, and 10.
 - g. Gain Switch High/Low. - Batteries, battery housing, meter; bias, Polarity, Collector Current, and Gain switch; Lever switch wafers a and b. Bias and Gain controls. External transistor terminals. See pictorials 2, 3, 4, 6, 7, 8, 9, and 10.

Specifications

DC beta	Two ranges: 0-200 and 200-400
Meter	2-1/2", 10-0-10 uA, 5000Ω
Internal power supply.	Collector voltage 9 volts, (6 size D-cells) Bias voltage: 1.5 volts (1 size D-cell).
External power supply*	Bias 0-5 Volts Collector: 0-50 volts DC Leakage 0-150 volts DC.
	*voltages that may be supplied to the external bias, collector, and leakage binding posts.
Dimensions.	5-1/2" high x 10-1/4" deep x 10-3/4" wide.
Net weight (without batteries).	8 lbs.

The heath company reserves the right to discontinue instruments and to change specifications at any time without incurring any obligation to incorporate new features in instruments previously sold.

Factory Repair Service

You can return your completed kit to the heath company service department to have it repaired for a minimum service fee. (Kits that have been modified will not be accepted for repair.) If you wish, you can deliver your kit to a nearby heath authorized service centre. These centres are listed in your Heathkit Catalog.

To be eligible for replacement parts under the terms of the warranty, equipment returned for factory repair service, or delivered to a heath authorized service centre,

must be accompanied by the invoice or the sales slip, or a copy of either. If you send the original invoice or sales slip, it will be returned to you.

If it is not convenient to deliver your kit to a heath authorized service centre, please ship it to the factory at Benton Harbor, Michigan and follow the following shipping instructions:

Prepare a letter in duplicate, containing the following information:

- your name and return address.
- date of purchase.
- a brief description of the difficulty.
- the invoice or sales slip, or a copy of either.

Your authorization to ship the repaired unit back to you C.O.D. for the service and shipping charges, plus the cost of parts not covered by the warranty.

Attach the envelope containing one copy of this letter directly to the unit before packaging, so that we do not overlook this important information. Send the second copy of the letter by separate mail to heath company, attention: service department, Benton Harbor, Michigan.

Check the equipment to see that all parts and screws are in place. (Do not include wooden cabinets when shipping receivers, tuners, amplifiers, or TV sets, as these are easily damaged in shipment.) Then, wrap the equipment in heavy paper. Place the equipment in a strong carton, and put at least three inches of resilient packing material (shredded paper, excelsior, etc.) on all sides, between the equipment and the carton. Seal the carton with gummed paper tape, and tie it with a strong cord. Ship it by prepaid express, United Parcel Service, or insured parcel post to:

Heath Company
Service Department
Benton Harbor, Michigan 49022

Circuit Description

Refer to the schematic diagram (fold-out from page 47) while reading the following description.

The circuit of this Transistor Tester consists of a voltage source, a meter, several switches, and two controls. When a transistor is being tested, the switches apply voltage and connect the meter to the proper elements of the transistor. Then the controls adjust the bias and provide the gain reading.

The voltage source consists of seven 1-½ volt D-cell batteries. One of these batteries supplies the bias voltage for the transistor. The other six batteries supply up to 9 volts to the collector of the transistor.

The collector voltage switch and the leak voltage switch select one or more of the series batteries to supply up to 9 volts in 1-½ volt steps. These switches also connect to two pairs of binding posts. The meter and circuit design permits external collector

voltage up to 50 volts, and external leak voltage up to 150 volts, to be applied to these binding posts for testing transistors at higher voltages.

Two silicon diodes are connected in parallel, but with their polarities in opposite direction, across the meter terminals. One of the diodes will conduct when the voltage across the meter reaches 6 volts. The polarity of the voltage determines which diode will conduct. Therefore, any large current will pass through the diodes and not the meter movement. This provides adequate protection for the meter.

The collector current and leak current switches select appropriate meter shunt resistors that increase the current range of the meter. Collector current ranges from 150 ma to 15 a, and leak current ranges from 15 ma to 1.5 a are selected by these switches.

The polarity switch determines the polarity of the voltage applied to test NPN or PNP transistors, and forward or reverse tests for diodes. The centre position of this switch disconnects the batteries from the circuit and places a short circuit across the meter. This direct short damps the meter movement to keep the pointer from swinging when the instrument is being moved.

Four lever switches select the test functions of the instrument. These test functions are:

- A (down) - Gain.
- A (up) - Base Current.
- B (down) - Collector Current.
- B (up) - Collector Voltage.
- C (down) - Short Test.
- C (up) - Leak Voltage.
- D (down) - Collector to Base Leak – I_{CBO} .
- D (up) - Diode Test, Collector to Emitter. Leak - I_{CEO} .

When any lever is actuated, its switch contacts connect the preset voltages and currents (selected by the rotary switches) to the proper elements of the transistor or diode and to the meter circuit.

The following paragraphs describe each test function separately. The individual schematics show the basic circuit for each test, without showing the complicated switch circuits. In these schematics, a PNP type transistor is shown. NPN transistor tests would be identical, except for reversed polarities.

Base Current test (I_B)

The meter is connected in series with the base circuit, therefore it shows base current directly. R_s (resistors R7 through R13) is the meter shunt which varies in value with the position of the leak-diode-base current switch. Collector voltage is selected with the collector voltage switch. Bias control R6 is adjusted for the specified base current.

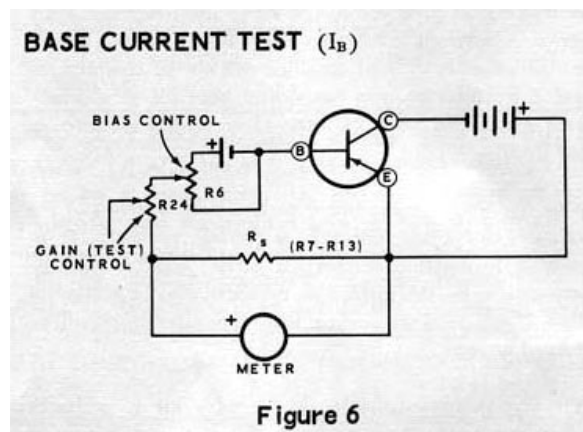

Figure 6

Gain Test (beta- h_{FE})

For this test, the ratio between the collector current and the base current is measured. The base current causes a voltage drop across gain test control R24. The collector current causes a voltage drop across R_s . The meter is connected from the collector side of R_s to the arm of R24.

The gain control is adjusted to null the meter, and at this point the current ratio (transistor gain) is indicated on the front panel gain dial. This dial is calibrated 0-200 and 200-400. When a transistor that has a gain of more than 200 is tested, the gain switch is placed in the high position. This switches resistance R_H (R15-R19) in series with R24 and extends the dial scale from 200 to 400.

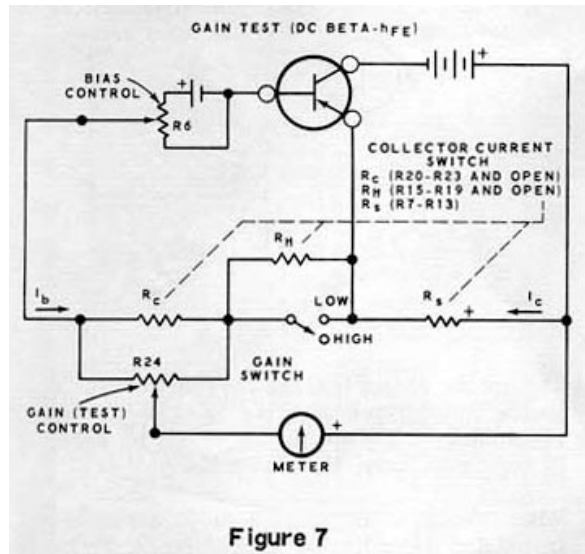

Figure 7

to test a transistor at higher currents, R_s (R7-R13) must be reduced in value. When R_s is changed, R_H and r_e must also be changed in the same proportion so the base and collector current ratio remains constant. The values of R_s , R_H , and R_c are selected by wafers of the collector current switch.

Collector Voltage Test (E_c)

The meter shows the voltage between the collector and the emitter. This voltage is selected with the collector voltage switch. R_v is the meter multiplier which is made up of resistors R1 through R5. This voltage is checked under DC operating conditions of the transistor.

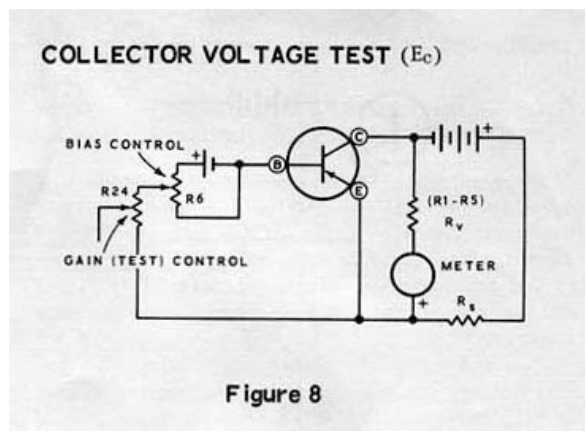

Figure 8

Collector Current Test (I_c)

This current is checked between collector and emitter as shown in figure 9. The bias control is adjusted for the desired collector current.

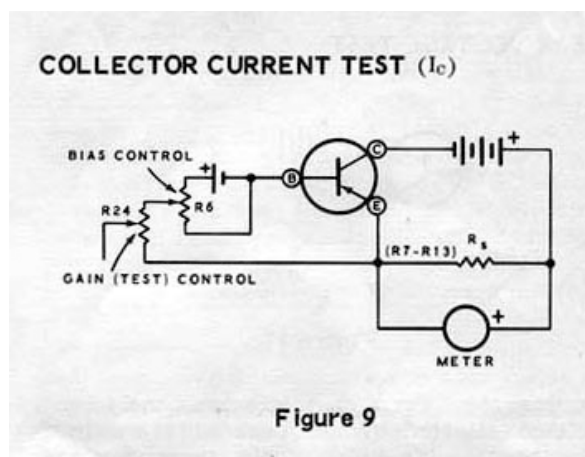
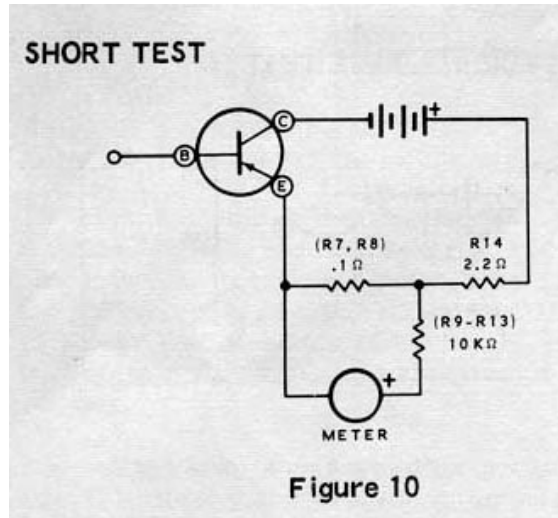

Figure 9

Short Test

Here, the voltage selected by the collector voltage switch is applied to the collector and emitter through series resistors R7, R8, and R14. The meter and its dropping resistors (R9-R13) is connected across R7 and R8, indicating any voltage drop in these resistors would be caused by a shorted transistor. R14 is a current limiting resistor.



Leak Voltage Test.

In this test, the meter measures the supply voltage selected by the leak voltage switch. The base and emitter of the transistor are open in this test.

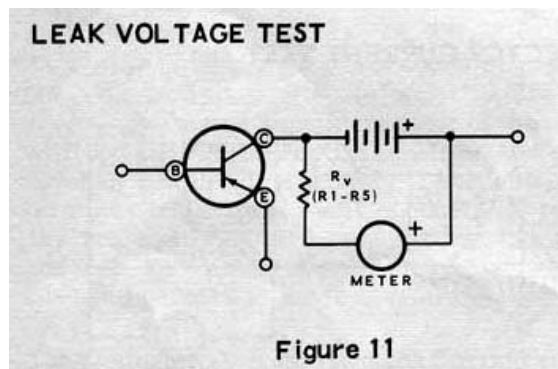

Collector to Emitter leakage (I_{CE0}) or Diode Test

The meter shows leakage current between collector and emitter with the base open. Again, resistance R_s is the meter shunt, as selected by the leak-diode-base switch.

When checking diodes, the diode replaces the transistor as indicated in figure 12. To check the forward current of a diode, the supply voltage is reversed with the polarity switch.

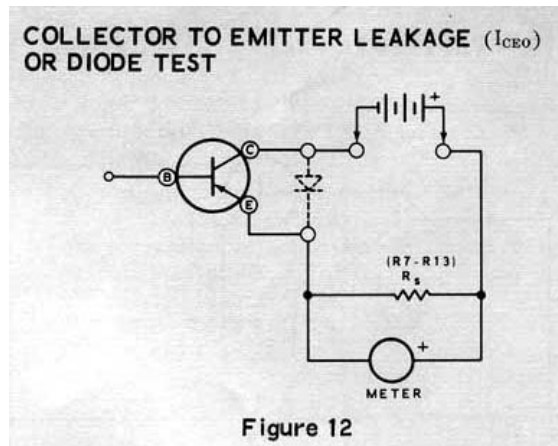

Collector to Base Leakage Test (I_{CBO})

In this test, the meter shows the leakage current between the collector and base with the emitter open. R_s is the meter shunt.

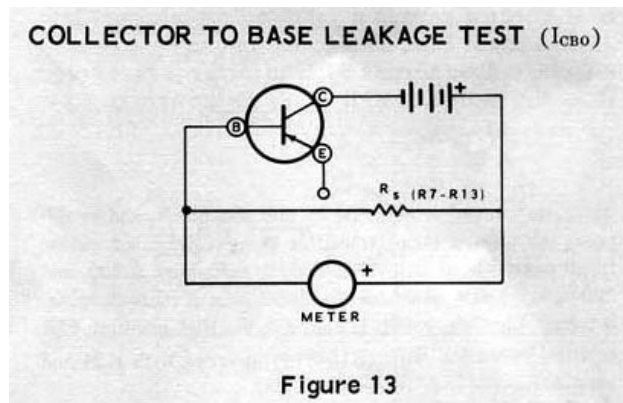

Replacement Parts Price List

To order parts, use the Parts Order Form furnished with this kit. If a parts order form is not available, refer to "replacement parts" in the "kit Builders Guide."

Part No.	Price	Description	Part No.	Price	Description
Resistors			Capacitor		
Precision 1%, 1/2 Watt			21-48	0.15	0.05 uF Disc
2-148	2.40	0.09Ω	Controls		
2-149	0.75	0.9Ω	11-75	1.80	20KΩ 2 Watt
2-229	0.70	9Ω	11-79	1.60	100Ω 4 Watt
2-19	0.20	18Ω	Switches		
2-230	0.20	18Ω	62-14	7.00	3 Position 6 Wafer, 4 Lever
2-24	0.20	90Ω	63-440	2.55	3-position 2-wafer rotary
2-231	0.20	180Ω	63-441	4.15	10-position 4-wafer rotary
2-29	0.20	900Ω	63-442	3.35	6-position 3-wafer rotary
2-232	0.20	1800Ω (1.8KΩ)	63-444	1.40	10-position 3-wafer rotary
2-233	0.20	2020Ω (2.02 KΩ)	60-4	0.20	SPDT Slide
2-35	0.20	9000Ω (9KΩ)	60-5	0.25	DPST Slide
2-189	0.20	18KΩ	Wire Harnesses & Wire		
2-156	0.20	145KΩ	134-138	1.55	Main Wire Harness
2-157	0.20	145KΩ	134-152	1.35	Battery Pack Wire Harness
2-14	0.20	1MΩ	134-153	0.70	Small Wire Harness
2-158	0.30	3.3 MΩ	344-6	.05/ft	Red Wire
2-17	0.40	10MΩ	344-59	.05/ft	White Wire
2 Watt					
2-15-2	1.00	2Ω 1%			
3-5-2	0.15	2.2Ω 10%			
Other Resistances					
340-12-1	0.05	0.01 Ω 1% Resistance Wire			

Part No.	Price	Description	Part No.	Price	Description
Hardware			75-17	0.10	Binding Post Base Insulator
#6 Hardware			100-16-2	0.10	Black Binding Post Cap
250-56	0.05	6-32x 1/4" Screw	100-16-18	0.10	Red Binding Post Cap
250-89	0.05	6-32x 3/8" Screw	462-97	0.10	Lever Switch Knob
250-8	0.05	#6 x 3/8" Sheet metal screw	462-245	0.25	Small Round Knob
255-23	0.10	6-32 threaded spacer	462-253	0.55	Large Pointer Knob
252-3	0.05	6-32 nut	455-50	0.10	Knob Bushing
252-22	0.05	6-32 Speednut	Metal Parts		
254-1	0.05	#6 Lockwasher	203-740-1	2.05	Panel
253-1	0.05	#6 fibre flat washer	90-502-2	4.25	Cabinet Shell
253-2	0.05	#6 Fibre shoulder washer	205-307-2	1.40	Rear Cover
259-1	0.05	#6 solder lug	214-14	0.80	Battery Housing
Other Hardware			204-413	0.75	Battery Spacing Bracket
250-175	0.05	2-56 x 3/8" screw	211-14	0.60	Handle
252-51	0.05	2-56 nut	Miscellaneous		
254-7	0.05	#3 lockwasher	56-10	0.85	Silicon Diode
4-40 Hardware			407-122	20.85	Meter (10-0-10 uA)
250-52	0.05	4-40 x 1/4" screw	434-116	0.55	Transistor Socket
252-2	0.05	4-40 nut	260-16	0.10	Alligator Clip
254-9	0.05	#4 lockwasher	438-14	0.55	Alligator Clip Adaptor
250-107	0.05	10-24 x 1/4" screw	261-4	0.05	Rubber Foot
254-3	0.05	#10 lockwasher	261-28	0.05	Plastic Foot
253-6	0.05	#10 flat fibre washer	207-18	0.10	3/8" Cable Clamp
Control Hardware			390-114	0.20	Battery Label
252-7	0.05	Control nut	490-5	0.10	Nut Starter
253-10	0.05	Control flat washer	331-6	0.15	Solder
254-4	0.05	Control lockwasher	595-861-03	2.00	Manual (see front cover for part number)
Binding Post & Knob Parts					
427-3	0.15	Binding Post Base			

The above prices apply only on purchases from the heath company where shipment is to a U.S.A. destination. Add 10% (minimum 25 cents) to the price when ordering from an authorized service centre or Heathkit electronic centre to cover local sales tax, postage and handling. Outside the U.S.A. parts and service are available from your local Heathkit source and will reflect additional transportation, taxes, duties and rates of exchange.

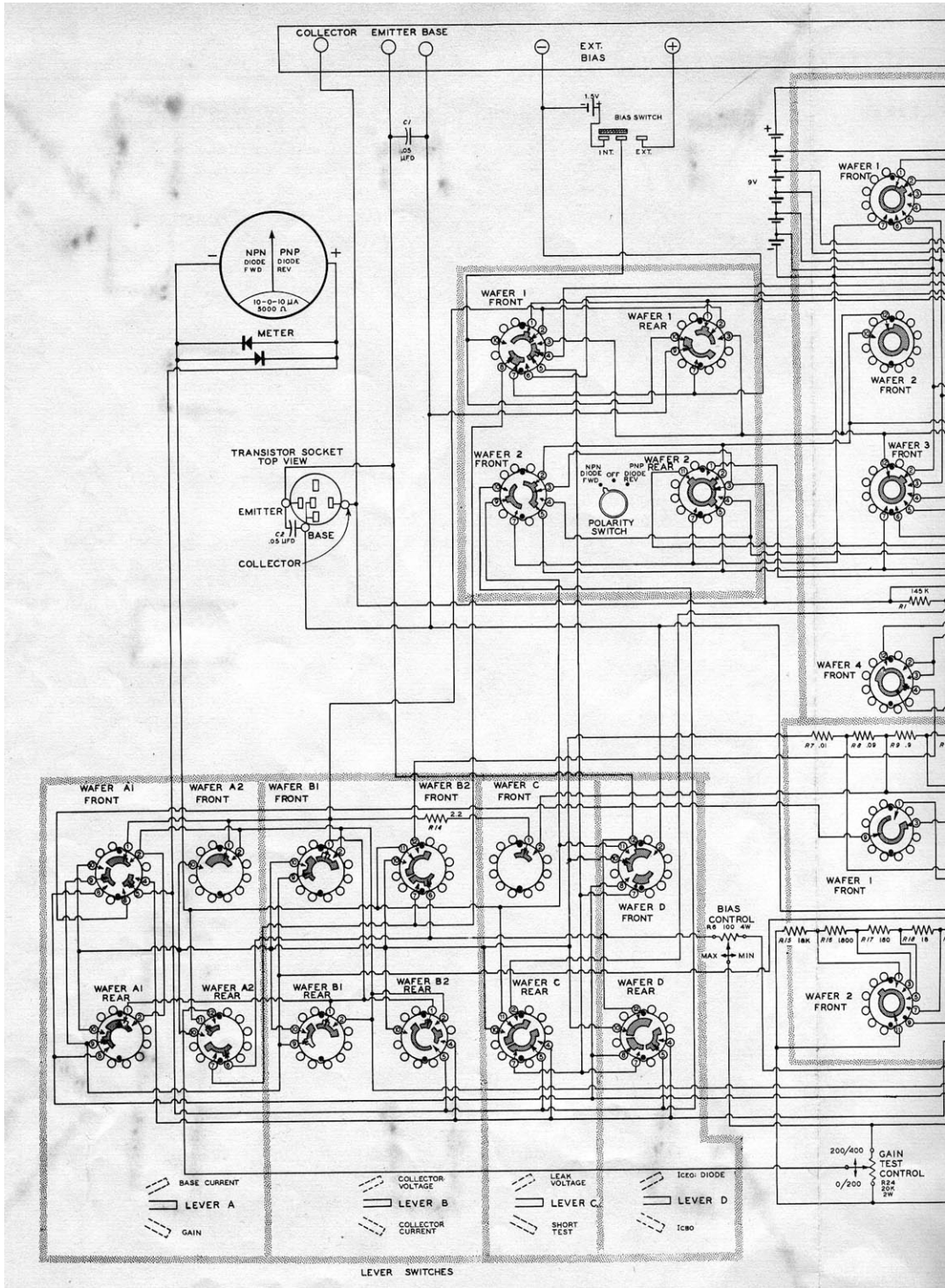

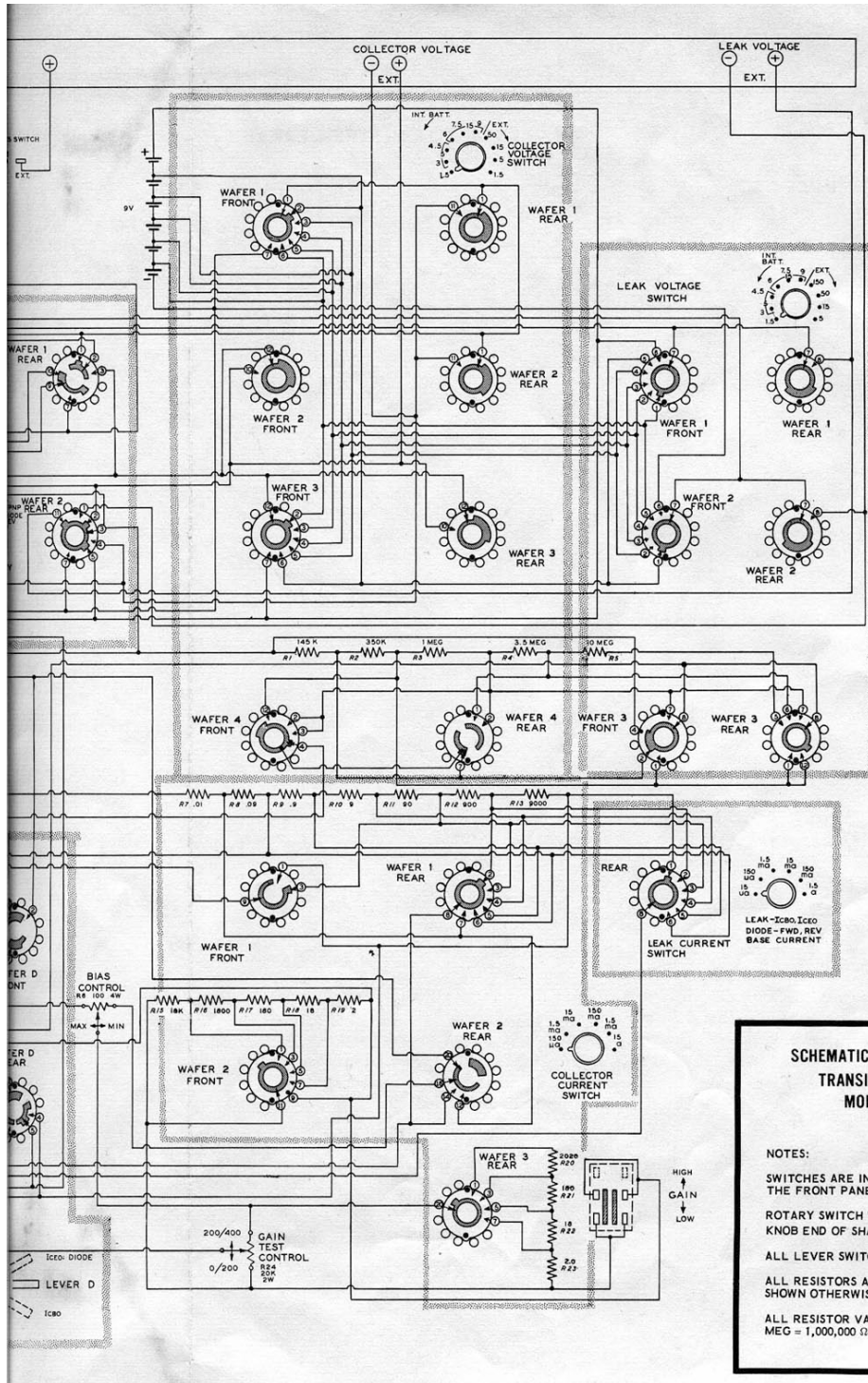

**SCHEMATIC OF THE HEATHKIT
TRANSISTOR TESTER
MODEL IM-36**

NOTES:

- SWITCHES ARE IN POSITIONS SHOWN BY THE FRONT PANEL MARKINGS.
- ROTARY SWITCH WAFERS ARE VIEWED FROM KNOB END OF SHAFT.
- ALL LEVER SWITCHES IN NEUTRAL POSITION.
- ALL RESISTORS ARE 1/2 WATT UNLESS SHOWN OTHERWISE.
- ALL RESISTOR VALUES ARE IN Ω (K = 1000 Ω , MEG = 1,000,000 Ω).